

BRAKES

PEDAL PADS AND RETURN SPRINGS

122289



57950

Part No.	Description	No. Off	Current Prices on Website
122289	Rubber Pad , brake and clutch pedals	2	
57950	Spring , pedal return	2	

FRONT BRAKE DISCS

“High-Performance Slotted and Spot Drilled”

High-performance brake discs are slotted and spot drilled. Slots draw cool air across the pad surface keeping pads and discs cooler. Spot drillings, as opposed to holes drilled right through the discs, break down surface gases when braking from high speed, but they do not weaken the cross-section of the disc which can lead to cracking of metal over time. The discs listed here will fit your stock hubs, and they will work with your stock calipers. Combine these rotors with the Greenstuff brake pads listed in the next section to maximize the efficiency of your braking system.

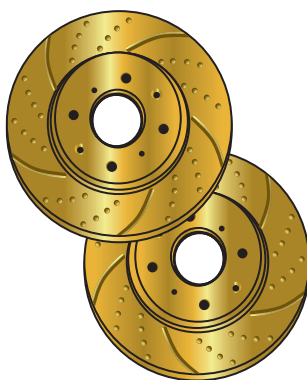

HP260

Part No.	Description	No. Off	Current Prices on Website
HP260	Front Brake Disc Kit , slotted and spot drilled, early TR4, up to comm. no. CT4689 (wire wheels) and CT4387 (disc wheels), 11-inch diameter	1	
RFK1720	Front Brake Disc Kit , slotted and spot drilled, later TR4, TR4A, after comm. no. CT4690 (wire wheels) and CT4388 (disc wheels), 10.75-inch diameter	1	

BRAKES

STOCK FRONT BRAKE DISCS (ROTORS)

209327

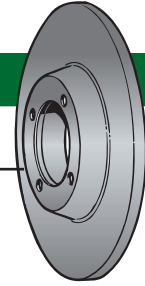

Part No.	Description	No. Off	Current Prices on Website
203189	Front Brake Disc , early TR4, up to comm. no. CT4689 (wire wheels) and CT4387 (disc wheels), 11-inch diameter	2	
209327	Front Brake Disc , later TR4, TR4A, after comm. no. CT4690 (wire wheels) and CT4388 (disc wheels), 10.75-inch diameter	2	
113150	Bolt , securing brake discs	8	
WL209	Washer , lock, securing brake discs	8	

BRAKE PADS

“TRF Offers Three Choices of Brake Pads”

Stock pads work well, semi-metallic work even better, and the EBC “Greenstuff” pads are better yet. Greenstuff pads are made of Kevlar which is a popular material for making brake pads for race cars. EBC Greenstuff pads are designed for fast road and mild race cars. You’ll notice a performance difference as soon as you install them.

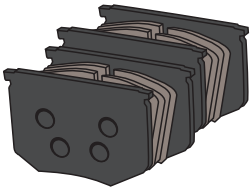

GIGP58

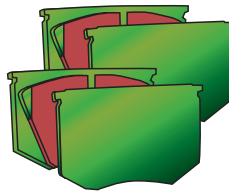

EBC151/GS

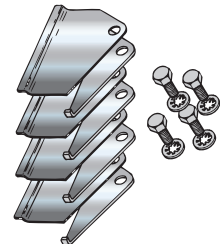

RFK547

Part No.	Description	No. Off	Current Prices on Website
	BRAKE PADS , early TR4, up to comm. no. CT4689 (wire wheels) and CT4387; TR3 type secured by metal plates and shims fitted to the top of the caliper		
GIGP58	Front Brake Pad Set , stock grade, early TR4	1	
EBC151/GS	Front Brake Pad Set , EBC “Green Stuff” Kevlar, early TR4	1	
RFK547	Retaining Kit , brake pads; includes retaining plates, anti-squeal shims, and hardware	1	

Section Continues On Next Page

BRAKES

BRAKE PADS—Continued

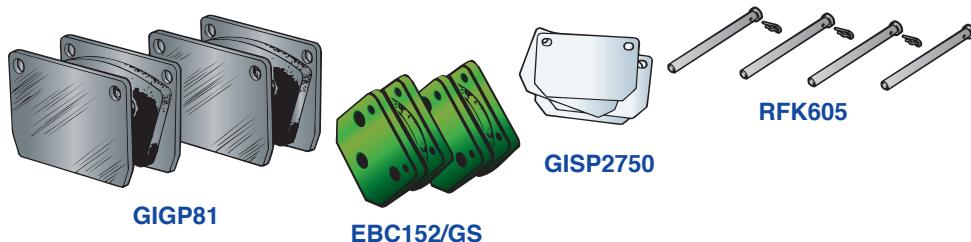

Part No.	Description	No. Off	Current Prices on Website
	BRAKE PADS , later TR4, TR4A, after comm. no. CT4690 (wire wheels) and CT4388 (disc wheels), TR4A; pads secured by pins through the pads		
GIGP81	Front Brake Pad Set , stock, later TR4, TR4A	1	
EBC152/GS	Front Brake Pad Set , EBC Brand “Green Stuff”: Kevlar, later TR4, TR4A	1	
TRFCD152	Front Brake Pads , semi-metallic, later TR4, TR4A	1	
GISP2750	Anti-squeal Shim Kit , later TR4, TR4A	1	
RFK605	Retaining Pin Kit ; includes four pins and four clips	1	

BRAKE DRUMS

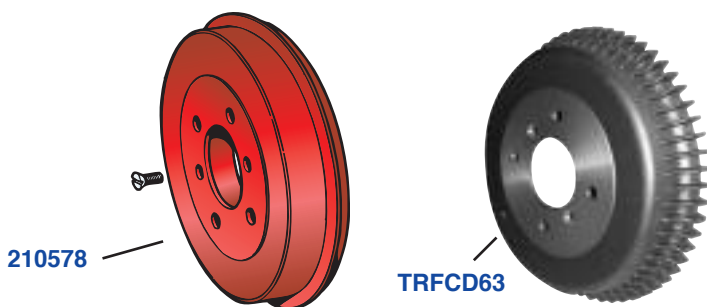

Part No.	Description	No. Off	Current Prices on Website
	STOCK GRADE BRAKE DRUMS		
201493	Brake Drum , solid axle cars, TR4, TR4A	2	
210578	Brake Drum , TR4A IRS only	2	
	FINNED ALUMINUM BRAKE DRUMS		
HP34	Brake Drum , finned aluminium, solid axle cars, TR4, TR4A	2	
TRFCD63	Brake Drum , finned aluminium, TR4A IRS only	2	
V5435	Screw , securing drums	4	

BRAKES

BRAKE SHOES

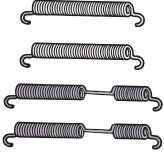
“New Shoes, Not Rebuilt”

GISRS8

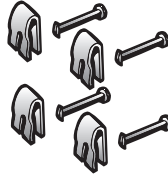

GISP1012

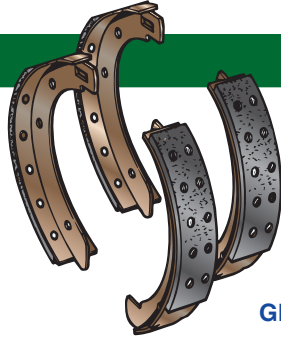

GBS778

Part No.	Description	No. Off	Current Prices on Website
GBS778	Brake Shoe Set	1	
GISP1012	Hold-down Kit , brake shoes; includes four spring clips and four pins	1	
GISRS8	Return Spring Kit , brake shoes; includes four shoe-return springs	1	

BRAKE FLUID AND BRAKE BLEEDING TOOLS

“LMA Brake Fluid is Original, Silicone Won’t Strip Your Paint if Spilled”

GILMA



SBF32



GIT20



RFT112



RFN1425

Part No.	Description	No. Off	Current Prices on Website
GILMA	Brake and Clutch Fluid , Castrol, 12 ounce bottle	A/R	
SBF32	Brake and Clutch Fluid , silicone, 32 ounce bottle	A/R	
BRAKE BLEEDING TOOLS			
GIT20	Visi-bleed ; Girling one-person bleeding system	1	
RFT112	Eezi-bleed , one-person bleeding system using air pressure from a spare tire	1	
RFN1425	Bottle , brake bleeder, 16 ounce bottle; includes cap, hose, and lanyard for keeping it in place while in use	1	

Please Note: Although silicone brake fluid has been successfully used for years by many enthusiasts, some brake manufacturers do not recommend its use, and new Girling cylinders have started to come with labels stating that warranty claims will not be honored if silicone fluid is used.

BRAKES

BRAKE MASTER CYLINDERS

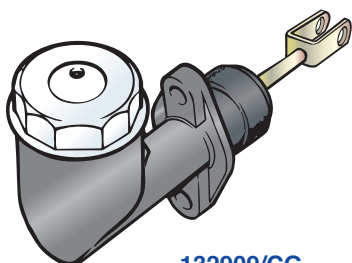

132909/CG



GISP2102



HK2102

Part No.	Description	No. Off	Current Prices on Website
	BRAKE MASTER CYLINDERS , early TR4 cars with wire wheels up to comm. no.CT5855 and cars with disc wheels up to comm. no. CT5782		
131661/TRW	Brake Master Cylinder , Girling, early TR4	1	
GISP1995	Repair Kit , brake master cylinder, Girling brand, early TR4, .75-inch bore	1	
HK1995	Repair Kit , brake master cylinder, aftermarket brand, early TR4, .75-inch bore	1	
	BRAKE MASTER CYLINDERS , later TR4, cars with wire wheels after comm. no.CT5855 and cars with disc wheels after comm. no. CT5782, all TR4A		
132909/TRW	Brake Master Cylinder , Girling, later TR4, TR4A	1	
132909/CG	Brake Master Cylinder , reproduction, later TR4, TR4A	1	
GISP2102	Repair Kit , brake master cylinder, Girling brand, later TR4, TR4A, .70-inch bore	1	
HK2102	Repair Kit , brake master cylinder, aftermarket brand, later TR4, TR4A, .70-inch bore	1	

Note: The later TR4, TR4A .70-inch bore brake master cylinders listed above can be fitted to early TR4's with .75-inch master cylinders

BRAKES

REBUILT FRONT CALIPERS



Our mechanic at C.A.R. Components rebuilds hundreds of Triumph calipers a year. Each caliper is disassembled, bead blasted, and painted. New seals and stainless steel pistons are installed. You have a choice of just having the caliper itself rebuilt, or you can buy a deluxe caliper which includes pads, hoses, retaining hardware, and anti-squeal shims. In addition, you have a choice of stock pads, semi-metallic pads (expect in the case of the early calipers), or high-performance Green Stuff pads. Call us at 800 234-1104, ext. 3010 to discuss core availability and to place your order. If you would like to have your rebuilt calipers a special color, talk to us about that. Employee owned cars at TRF always have red brake calipers, following a tradition that Charles Runyan began when he restored his black TR3A back in the early 1970's. Based on this, we have noticed that Porsche and Ferrari, among others, have copied our idea and have started painting their calipers red too.

From our research it appears that two different calipers were fitted to the TR4. The early cars seem to have been fitted with the same calipers as the later TR3A's. This is odd as the TR3B's seem to have gotten the calipers that were then fitted to later TR4's. The early calipers can be identified by the method of retaining the brake pads. Like the TR3A calipers, the pads slid in through the top of the caliper and were retained by shims and plates that were secured to the caliper with set screws. The later TR4 and the TR4A, had pads that were retained by pins that fit through the side of the caliper and through the pads themselves. Small clips were then used to retain the pins. To help sort out the differences, we have broken down listings into three sections—early TR4, later TR4, and TR4A.

C.A.R. Components is currently closed, but we will revise this page when it reopens.

Section Continues on Next Page

BRAKES

REBUILT FRONT CALIPERS—Continued



Part No.	Description	No. Off	Current Prices on Website
	REBUILT FRONT CALIPERS , early TR4 with Type B split calipers; pads are retained by metal plates and shims fitted to the tops of the calipers		
	REBUILT CALIPERS ; hoses, pads, and fittings not included		
206506R	Rebuilt Caliper , L.H. early TR4,	1	
CORE45	Core Charge on the above	1	
206507R	Rebuilt Caliper , R.H. early TR4,	1	
CORE45	Core Charge on the above	1	
	DELUXE REBUILT CALIPERS ; early TR4; includes rebuilt caliper, pads, retaining plates, shims, and hoses		
RBBC103/LH	Rebuilt Caliper Kit , L.H. early TR4, fitted with stock pads	1	
CORE45	Core Charge on the above	1	
RBBC103/RH	Rebuilt Caliper Kit , R.H. early TR4, fitted with stock pads	1	
CORE45	Core Charge on the above	1	
RBBCG103/LH	Rebuilt Caliper Kit , L.H. early TR4, fitted with high-performance Green Stuff pads	1	
CORE45	Core Charge on the above	1	
RBBCG103/RH	Rebuilt Caliper Kit , R.H. early TR4, fitted with high-performance Green Stuff pads	1	
CORE45	Core Charge on the above	1	

Please note: Semi-metallic pads are not available for the above caliper

Section Continues On Next Page

BRAKES

REBUILT FRONT CALIPERS—Continued

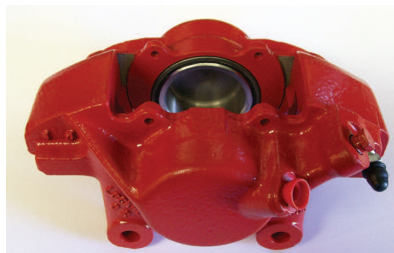

Part No. Description No. Off Current Prices on Website

REBUILT FRONT CALIPERS, later TR4 with

Type 16P calipers; pads are retained by pins and clips fitted through the sides of the caliper bodies and through the pads

REBUILT FRONT CALIPERS; pads, hoses, and fittings not included

GI64032288R	Rebuilt Caliper , L.H., later TR4,	1
CORE45	Core Charge on the above	1
GI64032289R	Rebuilt Caliper , R.H., later TR4,	1
CORE45	Core Charge on the above	1

DELUXE REBUILT CALIPERS; later TR4

includes rebuilt caliper, pads, anti-squeal shims, and hoses

RBBC104/LH	Rebuilt Caliper , L.H., later TR4;	1
	fitted with stock pads	
CORE45	Core Charge on the above	1
RBBC104/RH	Rebuilt Caliper , R.H., later TR4;	1
	fitted with stock pads	
CORE45	Core Charge on the above	1
RBBCG104/LH	Rebuilt Caliper , L.H., later TR4;	1
	fitted with high-performance Green Stuff pads	
CORE45	Core Charge on the above	1
RBBCG104/RH	Rebuilt Caliper , R.H., later TR4;	1
	fitted with high-performance Green Stuff pads	
CORE45	Core Charge on the above	1
RBBCS104/LH	Rebuilt Caliper , L.H., later TR4;	1
	fitted with high-performance semi-metallic pads	
CORE45	Core Charge on the above	1
RBBCS104/RH	Rebuilt Caliper , R.H., later TR4;	1
	fitted with high-performance semi-metallic pads	
CORE45	Core Charge on the above	1

Section Continues On Next Page

BRAKES

REBUILT FRONT CALIPERS—Continued

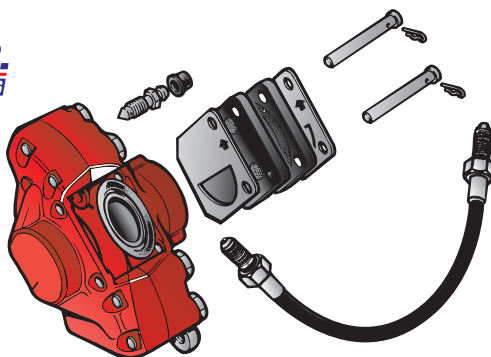

Part No.	Description	No. Off	Current Prices on Website
----------	-------------	---------	---------------------------

REBUILT FRONT CALIPERS, TR4A

with Type 16P calipers; pads are retained by pins and clips fitted through the side of the caliper bodies and through the pads

REBUILT FRONT CALIPERS; does not include pads, hoses or fittings

GI64032288R	Rebuilt Caliper, L.H., TR4A	1	
CORE45	Core Charge on the above	1	
GI64032289R	Rebuilt Caliper, R.H., TR4A,	1	
CORE45	Core Charge on the above	1	

DELUXE REBUILT CALIPERS;

TR4A includes rebuilt caliper, pads, anti-squeal shims, and hoses

RBBC105/LH	Rebuilt Caliper, L.H., TR4A; fitted with stock pads	1	
CORE45	Core Charge on the above	1	
RBBC105/RH	Rebuilt Caliper, R.H., TR4A; fitted with stock pads	1	
CORE45	Core Charge on the above	1	
RBBCG105/LH	Rebuilt Caliper, L.H., TR4A; fitted with high-performance Green Stuff pads	1	
CORE45	Core Charge on the above	1	
RBBCG105/RH	Rebuilt Caliper, R.H., TR4A; fitted with high-performance Green Stuff pads	1	
CORE45	Core Charge on the above	1	
RBBCS105/LH	Rebuilt Caliper, L.H., TR4A; fitted with high-performance semi-metallic pads	1	
CORE45	Core Charge on the above	1	
RBBCS105/RH	Rebuilt Caliper, R.H., TR4A; fitted with high-performance semi-metallic pads	1	
CORE45	Core Charge on the above	1	

BRAKES

FRONT CALIPER REBUILDING COMPONENTS,
all TR4, TR4A

HK2501



HP126/E



GISP2501



GI64470444



234957A

Part No.	Description	No. Off Current Prices on Website
GISP2501	Repair Kit , front brake caliper, TR4, TR4A, Girling brand	1
HK2501	Repair Kit , front brake caliper, TR4, TR4A, quality aftermarket kit	1
HP126/E	Piston , brake caliper, stainless steel	4
GI64470444	Bleeder Screw , front caliper	2
234957A	Dust Cover , bleed screw	2

REAR WHEEL CYLINDERS

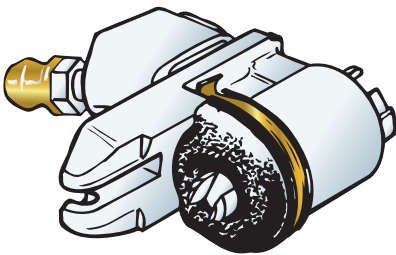

GI64674185

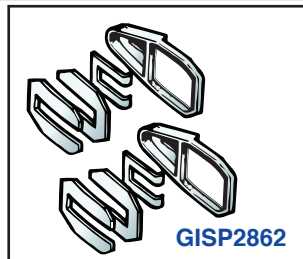

GISP2862



505093A

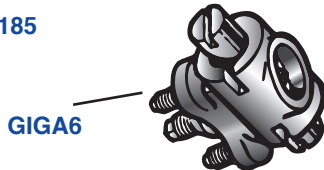

GIGA6



HK2083

Part No.	Description	No. Off Current Prices on Website
GI64674185	Wheel Cylinder , rear, .70 inch	2
HK2083	Repair Kit , rear wheel cylinder	1
GISP2862	Installation Kit , for rear wheel cylinders; includes spring plates and dust covers	1
505093A	Dust Cover , rear wheel cylinder; included in kit listed above	2
GIGA6	Brake Adjuster	2

BRAKES

BRAKE PIPES, TR4 only

Several changes occurred during the production of the TR4 that make the listing of brake pipes difficult. Sorting through the factory parts catalogue listings is further complicated by some obvious errors and contradictions. We feel that the following listings are accurate and would appreciate any customer feedback to fine tune what we have listed here.

It appears that there were two significant change points as listed here. Up to comm. no. CT4689 (cars with wire wheels) and CT4387 (cars with disc wheels), TR3A type split calipers were fitted. These are easily identified by the method of securing the brake pads. On these calipers, metal plates and shims are bolted to the tops of the calipers to retain the pads. After this point one-piece calipers were fitted in which the brake pads are retained by pins fitted through the pads. At comm. no. CT26930 the fitting on the chassis at the front of the car was changed from a five-way fitting to a four-way fitting. On cars with the five-way fitting, the brake switch was hydraulically activated and was fitted to the five-way fitting. On cars after CT26930, it appears that a four-way fitting was used and the brake switch became a push-button type electrical switch that was fitted to the brake master cylinder bracket and was operated by the master cylinder push rod.

Pipes listed in the following sections are steel brake lines with all correct flares and fittings. Pipes are coiled and are easily bent to shape.

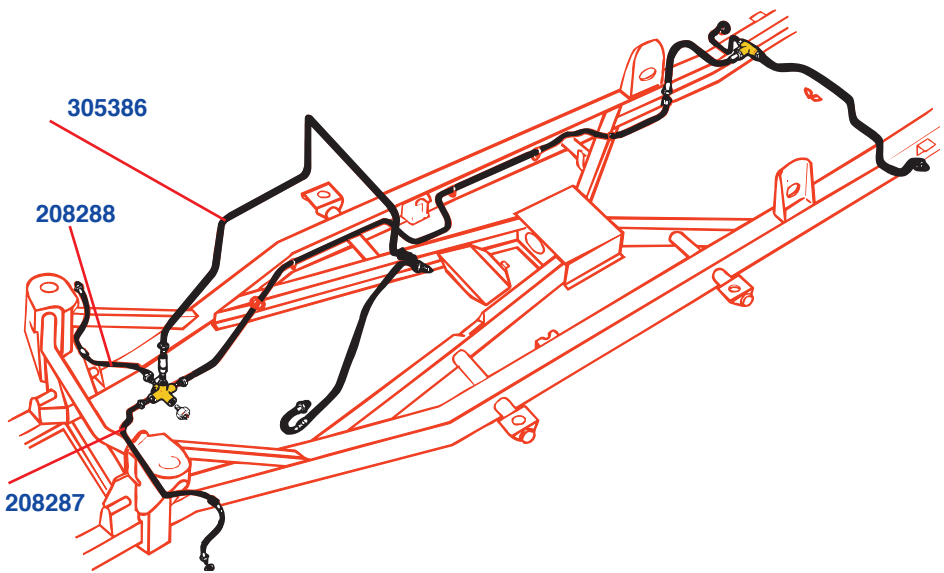

Part No.	Description	No. Off	Current Prices on Website
305386	Pipe , from brake master cylinder to fitting mounted on R.H. frame member; five-way fitting on early cars, four-way fitting on later cars	1	
PIPES FROM FITTING ON FRAME TO HOSE BRACKET , early fitment up to comm. no. CT4689 (wire wheels) and CT4387 (wire wheels)			
208287	Pipe , from five-way fitting to frame bracket for L.H. front brake hose, early	1	
208288	Pipe , from five-way fitting to frame bracket for R.H. front brake hose, early	1	

Section Continues On Next Page

BRAKES

BRAKE PIPES, TR4 only—Continued

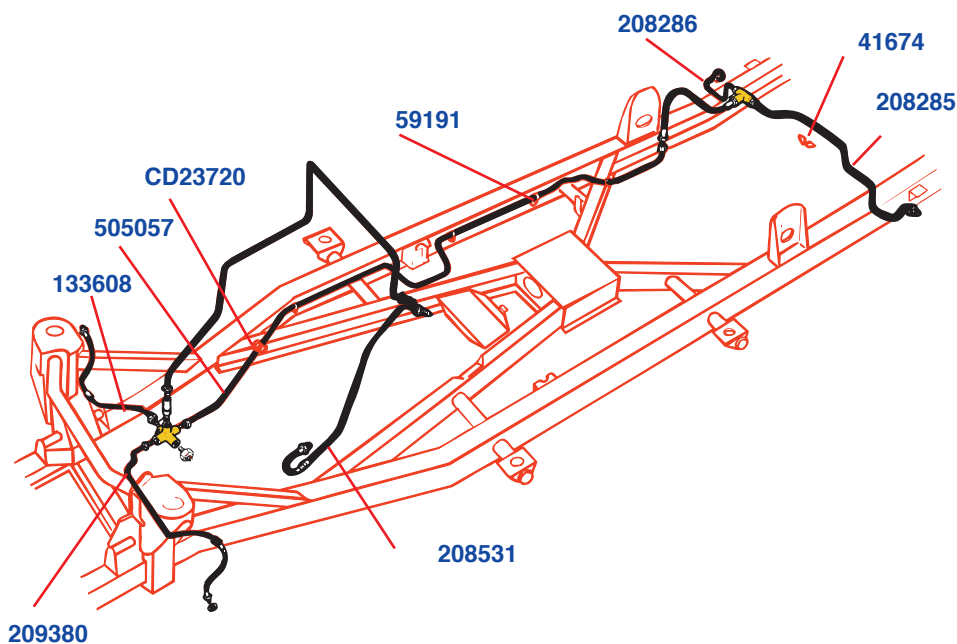

Part No.	Description	No. Off	Current Prices on Website
----------	-------------	---------	---------------------------

PIPES FROM FITTING ON FRAME TO

HOSE BRACKET, later fitment after comm. no. CT4689 (wire wheels) and CT4387 (wire wheels)

209380	Pipe , from five-way or four-way fitting to frame bracket for L.H. front brake hose, later	1	
133608	Pipe , from five-way or four-way fitting to frame bracket for R.H. front brake hose, later	1	
505057	Pipe , from front fitting to three-way fitting on frame bracket adjacent to rear axle	1	
CD23720	Grommet , on chassis	2	
59191	Clip , pipe to chassis	3	
208285	Pipe , from three-way fitting on rear axle to L.H. rear brake cylinder	1	
208286	Pipe , from three-way fitting on rear axle to R.H. rear brake cylinder	1	
41674	Clip , rear brake pipes to axle	3	

CLUTCH HYDRAULIC PIPES

208531	Clutch Pipe , from master cylinder to frame bracket for hose to clutch slave cylinder	1	
--------	--	---	--

BRAKES

BRAKE PIPES, TR4A solid axle only

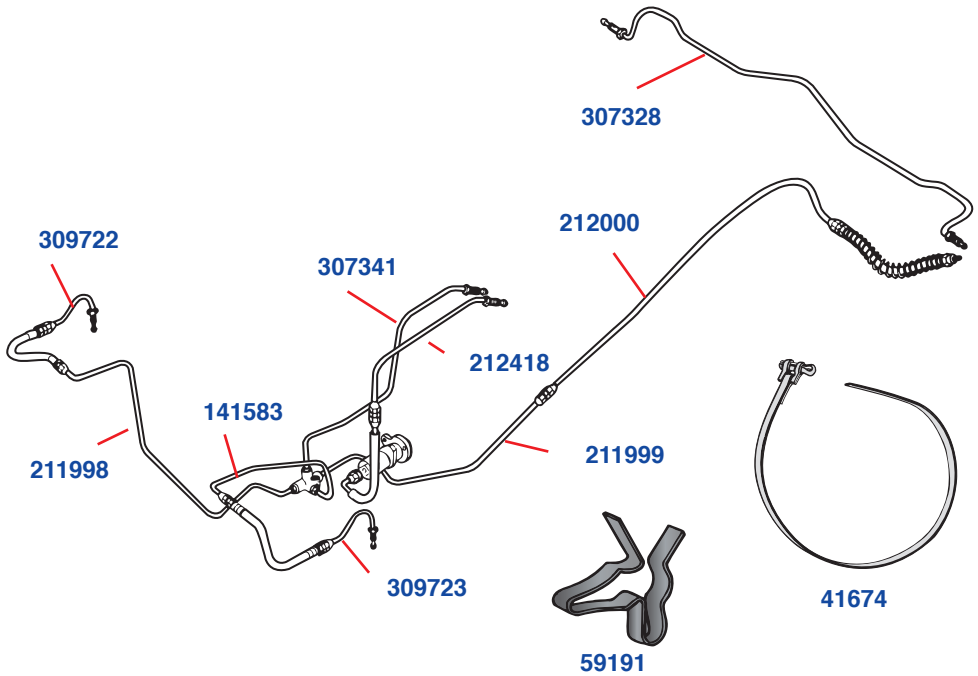

Part No.	Description	No. Off	List Price	Sale Price
----------	-------------	---------	------------	------------

BRAKE HYDRAULIC PIPES

307341	Pipe , from brake master cylinder to four-way fitting on L.H. frame sidemember	1		
141583	Pipe , from four-way fitting to frame bracket for hose to L.H. front brake caliper	1		
141590	Pipe , from hose to L.H. front brake caliper	1		
211998	Pipe , from four-way fitting to frame bracket for hose to R.H. front brake caliper	1		
141590	Pipe , from hose to R.H. front brake caliper	1		
211999	Pipe , from four-way fitting to double-ended union for rear brakes	1		
59191	Clip , pipe to chassis	3		
212000	Pipe , from two-way fitting to bracket on frame for hose to L.H. rear wheel cylinder	1		
307328	Pipe , from L.H. rear wheel cylinder to R.H. rear wheel cylinder	1		
41674	Clip , pipe to axle housing	2		

CLUTCH HYDRAULIC PIPES

212418	Clutch Pipe , from clutch master cylinder to hose for clutch slave cylinder	1		
--------	--	---	--	--

BRAKES

BRAKE PIPES, TR4A IRS only

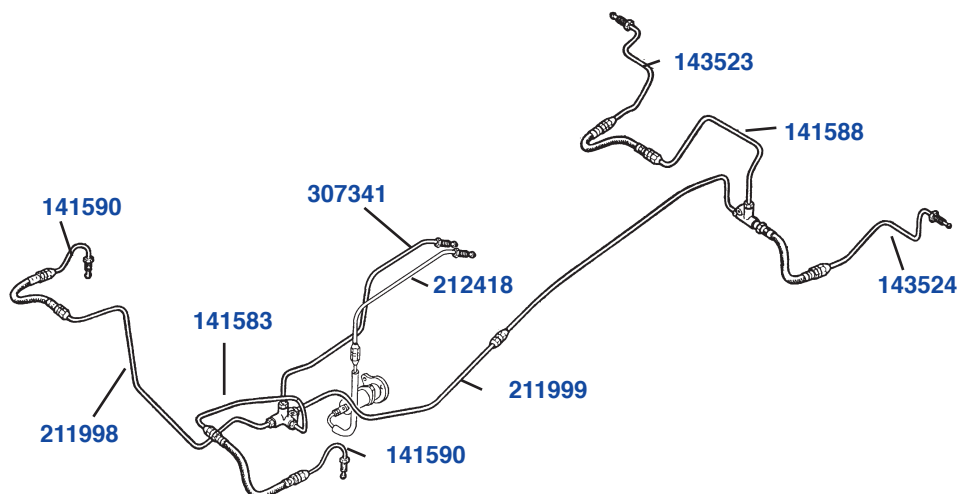

Part No.	Description	No. Off	Current Prices on Website
----------	-------------	---------	---------------------------

BRAKE HYDRAULIC PIPES

307341	Pipe , from master cylinder to four-way fitting on L.H.frame sidemember	1	
141583	Pipe , from four-way fitting to frame bracket for hose to L.H. front brake caliper	1	
141590	Pipe , from hose to L.H. front brake caliper	1	
211998	Pipe , from four-way fitting to frame bracket for hose to R.H. front brake caliper	1	
141590	Pipe , from hose to R.H. front brake caliper	1	
211999	Pipe , from four-way fitting to double-ended union for rear brakes	1	
59191	Clip , pipe to chassis	3	
212448	Pipe , from double-ended union to three-way fitting on L.H rear sidemember of frame adjacent to rear axle	1	
141588	Pipe , from three-way fitting across frame to bracket on R.H. rear sidemember of frame for hose to R.H.rear brakes	1	
143523	Pipe , from flexible hose to R.H. rear wheel cylinder	1	
143524	Pipe , from flexible hose to L.H. rear wheel cylinder	1	

CLUTCH HYDRAULIC PIPES

212418	Clutch Pipes , from clutch master cylinder to clutch slave cylinder flexible hose	1	
--------	--	---	--

BRAKES

BRAKE HYDRAULIC HOSES



GBH122

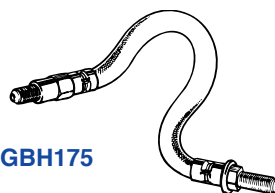

GBH175

Part No.	Description	No. Off	Current Prices on Website
	BRAKE HOSES , early TR4 up to comm. no. CT4689 (wire wheels) and CT4387 (disc wheels); cars with early calipers in which the brake pads are secured by plates and shims bolted to the top of the caliper		
GBH175	Brake Hose , front, early TR4	2	
GBH122	Brake Hose , rear, TR4	1	
	BRAKE HOSES , later TR4, after comm. no. CT4690 wire wheels) (and CT4388 (disc wheels), cars with later caliper in which the pads are secured by pins through the pads		
GBH206	Brake Hose , front, later TR4	2	
GBH122	Brake Hose , rear, TR4	1	
	BRAKE HOSES , TR4A solid axle only		
GIGHP13	Brake Hose , front, solid axle TR4A	2	
GBH216	Brake Hose , rear, solid axle TR4A	1	
	BRAKE HOSES , TR4A IRS only		
GIGHP13	Brake Hose , front, TR4A IRS	2	
GIGHP15	Brake Hose , rear, L.H., TR4A IRS	1	
GIGHP14	Brake Hose , rear, R.H., TR4A IRS	1	

BRAKES

BRAKE HYDRAULIC HOSES—BRAIDED METAL HOSES

“Braided Metal Hoses Are a Must for High-Performance Cars, Extra Insurance for Street Use”

Racers always use braided metal hoses. Braided metal hoses provide a harder brake pedal, as the walls of the hoses do not flex. Braided metal hoses are extra insurance against chafing or accidental damage from road debris.



HPK102

Part No.	Description	No. Off	Current Prices on Website
	BRAIDED HOSE KITS, TR4		
HPK107	Hydraulic Hose Kit , braided metal hoses, early TR4, for use with calipers on which the brake pads are secured by metal plates to the tops of the caliper	1	
HPK113	Hydraulic Hose Kit , braided metal hoses, later TR4, for use with calipers on which the brake pads are secured with pins through the pads	1	
	BRAIDED HOSE KITS, TR4A		
HPK111	Hydraulic Hose Kit , braided metal hoses, TR4A solid axle cars	1	
HPK102	Hydraulic Hose Kit , braided metal hoses, TR4A IRS cars	1	

BRAKES

HANDBRAKE LEVER RUBBER GRIPS AND BOOTS

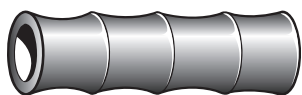

131312

705402



610942

Part No.	Description	No. Off	Current Prices on Website
131312	Handle Grip , rubber	1	
	RUBBER BRAKE BOOT DETAILS, TR4 only		
705402	Rubber Boot , handbrake lever	1	
610942	Steel Plate , securing rubber boot to floor	1	
RFK1891	Fitting Kit , brake boot and plate to floor	1	

HANDBRAKE CABLES

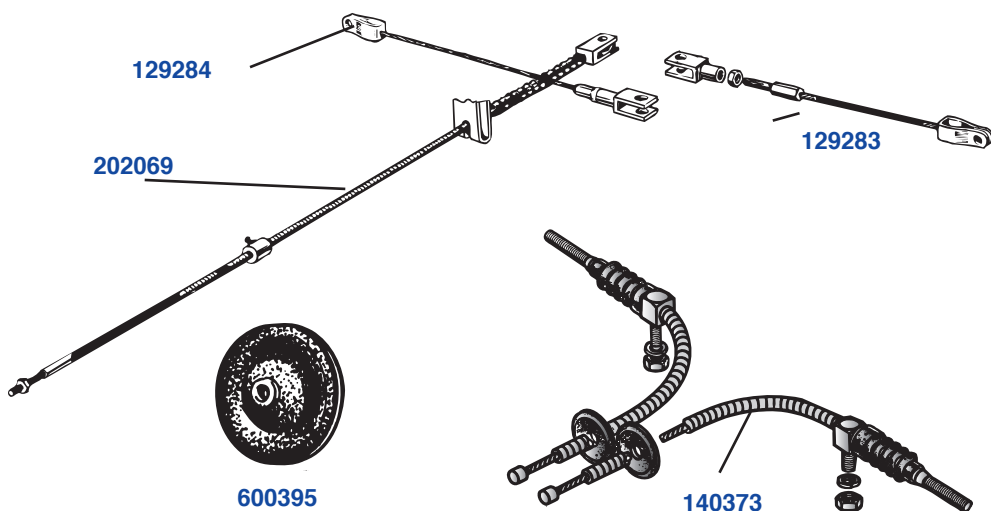

Part No.	Description	No. Off	Current Prices on Website
	HANDBRAKE CABLES, TR4 only		
202069	Main Brake Cable	1	
129283	Rear Brake Cable , long, L.H.	1	
129284	Rear Brake Cable , short, R.H.	1	
	HANDBRAKE CABLES, TR4A		
140373	Handbrake Cable	2	
600395	Grommet , rubber, sealing holes in rear heelboard	2	

WHEELS

DAYTON BRAND WIRE WHEELS

“Simply the Best Wire Wheels Available”

The Roadster Factory handles only Dayton Brand Wire Wheels for the TR4 and TR4A. Dayton wheels are made in Dayton, Ohio, U.S.A., and they are the best Dunlop-style wheels available in the world today. That is why TRF stocks them and recommends them to our customers. They are rounder, stronger, better built, and better finished than other wheels on the market. Other brands often require re-truing of spokes before they can be balanced for installation on your car. Are you going to have them trued at your local wire wheel shop? Do you have one in your area? Your Dayton wire wheels purchased from The Roadster Factory will probably never require re-truing!

Chromed wire wheels have polished stainless steel spokes that look like chrome but are stronger than chromed steel spokes.

The Roadster Factory can supply any wheels offered by Dayton Wire Wheels. For other applications, call Level 2 Sales at 800 234-1104.



WWH60151



WWH60152

Part No.	Description	No. Off Current Prices on Website
WWH60151	Wire Wheel , tube-type, painted, 15 x 4.5, 60 spoke	4 or 5
WWHDB60-155P	Wire Wheel , tubeless-type, painted, 15 x 5, 60 spoke	4 or 5
WWH60152	Wire Wheel , tube-type, chromed wheel with polished stainless steel spokes, 15 x 4.5, 60 spoke	4 or 5
WWHDB60-155C	Wire Wheel , tubeless-type, chromed wheel with polished stainless steel spokes, 15 x 5, 60 spoke	4 or 5

Wire Wheel Shipping—TRF ships sets of four or five wheels for just \$60.00 to the contiguous 48 states. This is the only deal ever offered on wire wheel shipping

WHEELS

WIRE WHEELS—HUB ADAPTORS

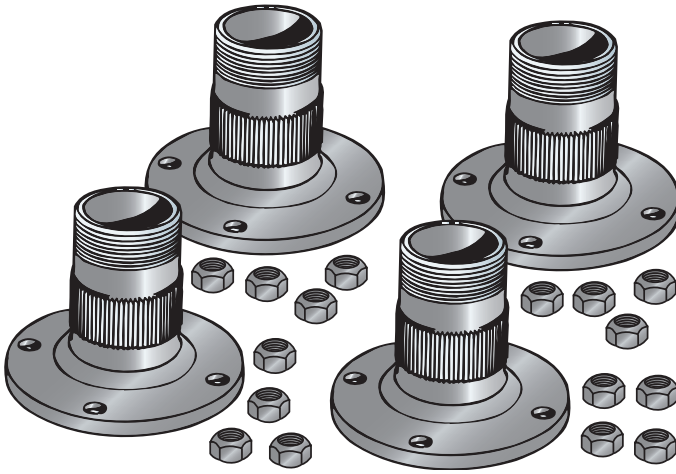

RFK1672

Part No.	Description	No. Off	Current Prices on Website
RFK1672	HUB ADAPTOR KIT; includes a set of four hub adaptors and sixteen special nuts	1	
217603	Hub Adaptor, L.H.	2	
217602	Hub Adaptor, R.H.	2	
110366	Special Bolt, securing hub adaptors	16	

If you are converting from disc wheels to wire wheels, the studs on the front and rear hubs must be shortened. You can do this by installing the hub adaptors with the special nuts and then hack-sawing the ends of the studs flush with the special nuts, or you can change the studs from the disc wheel type to the shorter wire wheel type.

WHEELS

WIRE WHEELS—RELATED COMPONENTS

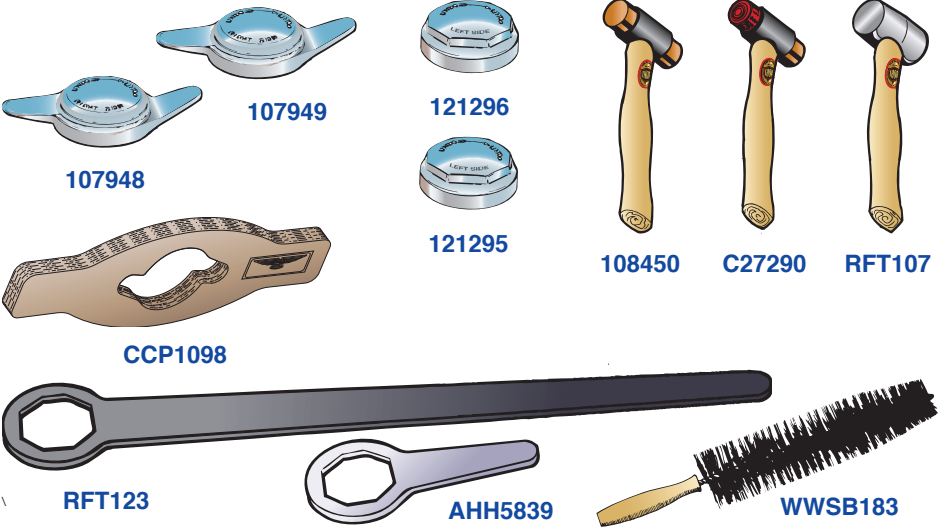

Part No.	Description	No. Off	Current Prices on Website
----------	-------------	---------	---------------------------

CENTER-LOCK NUTS—KNOCK-OFF

NUTS, two-eared nuts were used on all TR4, TR4A, we are also listing octagonal nuts for those who prefer that type

107949	Center-lock Nut , chromed, two-eared, L.H.	2	
107948	Center-lock Nut , chromed, two-eared, R.H.	2	
121296	Center-lock Nut , chromed, octagonal, L.H.	2	
121295	Center-lock Nut , chromed, octagonal, R.H.	2	

WIRE WHEEL TOOLS**THOR HAMMERS**

108450	Thor Hammer , smaller size, two copper faces, Triumph type	1	
C27290	Thor Hammer , larger size, one copper face and one leather face, Jaguar type	1	
RFT107	Thor Hammer , smaller size, with lead head	1	

WRENCHES

AHH5839	Knock-off Wrench , for octagonal knock-offs	1	
CCP1098	Knock-off Wrench , for eared knock-offs; made with laminated wood to protect your nuts	1	
RFT122	Knock-off Wrench , long-handled, for two eared-nuts	1	
RFT123	Knock-off Wrench , long-handled, for octagonal nuts	1	
WWSB183	Cleaning Brush , spokes	1	

WHEELS

PANASPORT WHEELS

Panasport has been supplying alloy wheels for Triumph for so long that many feel that they were an original option. Maybe they should have been. Very high quality wheels that will make your Triumph look and drive good. Good alternative for bent original steel wheels. Each wheel includes chromed nuts and center caps

Available again in colours, gold and black, call 800-234-1104 for details

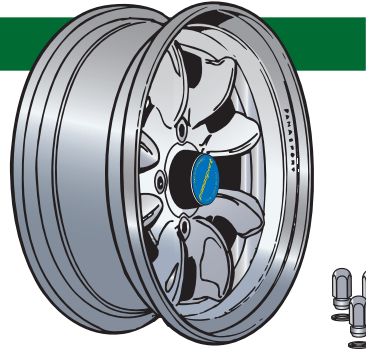

PANFS1506/SVR

Part No.	Description	No. Off	List Price	Your Price
PANFS1555/SVR	Panasport Wheel , 15 x 5.5, silver	4-5		
PANFS1506/SVR	Panasport Wheel , 15 x 6, silver	4-5		

CENTER LOCK ALLOY RACING WHEELS

Note: The Panasport Wheels Sold By TRF Are For Street and Highway Use Only. These Wheels Might Not be Approved for Competition and Racing Organizations



KNK1555/ANC

Part No.	Description	No. Off	List Price	Your Price
	ALLOY WHEELS , knock-off type; fits standard wire wheel hub splines			
KNK1555/SVR	Road Wheel , alloy, knock-off type, 15 X 5.5 inches; silver finish	4-5		
KNK1555/ANC	Road Wheel , alloy, knock-off type, 15 X 5.5; anthracite (dark grey) finish	4-5		

ACCU GAUGE TIRE PRESSURE GAUGE

“The Nicest We Have Seen”



RFT127

Part No.	Description	No. Off	List Price	Your Price
RFT127	Accu-Gauge Tire Pressure Gauge; high-quality pressure gauge with a hose and the ability to bleed off air to adjust tire pressures accurately	1		