

WEATHER EQUIPMENT

ROBBINS BRAND CONVERTIBLE TOPS, TR250, TR6

“We at TRF Consider Robbins Brand Tops to Be the Best Overall...”

The Roadster Factory has been handling Robbins brand tops since the 1980's, we have visited the Robbins factory in California a number of times, and we believe that the Robbins tops are the best overall with regard to quality, value for money, range of choices, and other factors, including good response to warranty issues. For TR250 and TR6, Robbins makes tops with reflective stripes identical to original Triumph tops in the U.S. market and tops without reflective stripes for international markets and for those who don't desire them, Robbins also makes tops with and without zip-out rear windows, and a range of materials and colours is offered with a corresponding range of prices. The most common materials are Robbins own vinyl top material, which tends to be a little stiff in cold weather, British Everflex vinyl material, and a deluxe canvas topping material which we call Sunfast. Each material comes in its own range of colours, and TRF offers the widest range of materials and colours of any British parts vendor.

My own favourite material has just been discontinued. We knew it as a black Everflex material with black canvas backing, but it now appears that it may not have been Everflex after all. Still it was very nice, and I have it on both my TR5 and my TR6 with both having been mistaken for original Triumph tops on many occasions. Although this material has been discontinued, I am going to keep the listings in the catalogue at the end of this section with the idea of looking for a replacement material. In the mean time, customers looking for a vinyl top with a black backing can use the Robbins material which has a good grain for TR250 and TR6, although it is a rather stiff material in cold weather as intimated above. And there are many other choices, including other Everflex materials, most of which have either tan or grey backing and Sunfast canvas material which usually comes with tan or black backing. Both of these are available in a wide variety of colours, and all colours are available with or without the reflective striping offered originally in the U.S. market. Both Everflex and Sunfast canvas are good materials for customers living in cooler climates.

Most Robbins tops are made to order for TRF customers, although we keep some of the fastest moving colours and models in stock. This gives our customers the full range of colour and material choices, and it insures that a factory-fresh product will be delivered every time. Material samples are available at no charge, but we request that customers let us know the colours they desire when requesting samples.



TR5 Sporting a Brand New Robbins Top

WEATHER EQUIPMENT

ROBBINS DELUXE CONVERTIBLE TOPS IN THREE MATERIALS, WITH REFLECTIVE STRIPES, TR250, TR6

“Large Selection of Colours Available”

We at The Roadster Factory believe that these Robbins tops are the best original style replacement tops on the market for TR250 and TR6 models. You have a choice of Robbins material which looks much the same as original English vinyl, or Everflex which is a very fine convertible top material made in England and originally developed for Rolls Royce, or Sunfast canvas cloth material, a very fine canvas topping material. Material and colour samples are available upon request. Please ask for specific materials and colours when requesting samples.

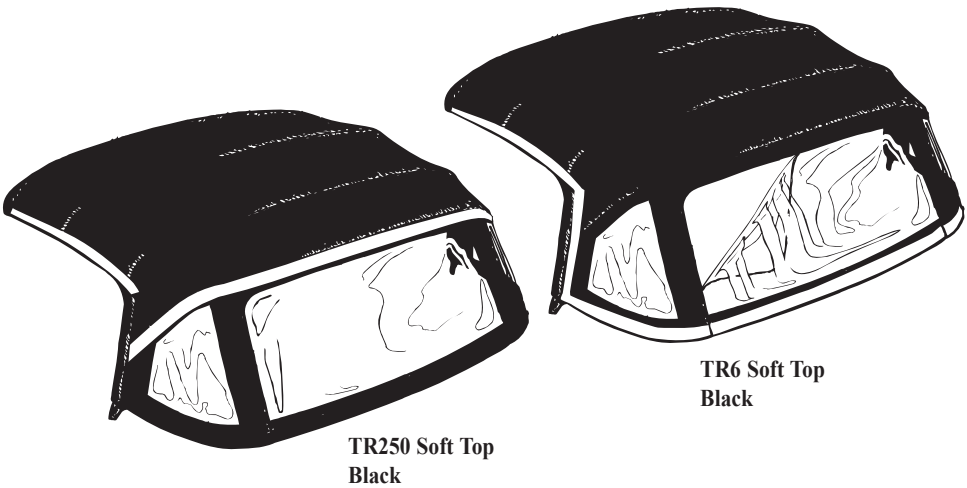

Part No.	Description	No. Off	List Price	Your Price
----------	-------------	---------	------------	------------

TOPS MADE FROM ROBBINS MATERIAL;

please specify colour desired, black, white, khaki tan, or caramel tan

RB2219	Deluxe Top , TR250; fixed rear window as original; correct reflective striping for TR250	1		
RB2219/A	Deluxe Top , TR250; zip-out rear window; correct reflective striping for TR250	1		
RB2220	Deluxe Top , TR6; zip-out rear window as original; correct reflective striping for TR6	1		

Note: Printed colours are approximations of actual convertible, tonneau and boot materials. Free samples available.

Section Continues ►►

WEATHER EQUIPMENT

ROBBINS DELUXE CONVERTIBLE TOPS IN THREE MATERIALS, WITH REFLECTIVE STRIPES, TR250, TR6

—Continued

Note: Printed colours are approximations of actual carpet and vinyl materials. Free samples available.

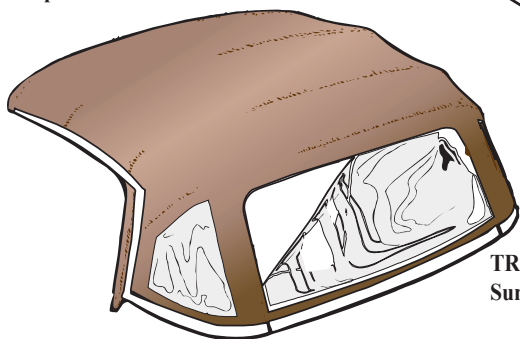

TR6 Soft Top
Sunfast, Tan

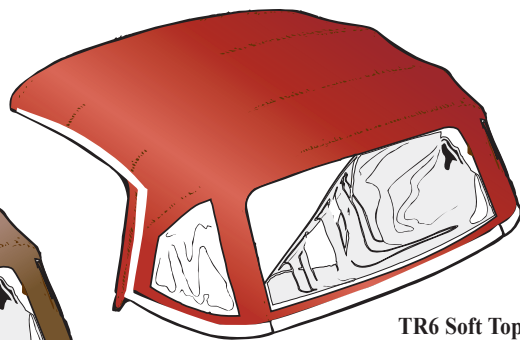

TR6 Soft Top
Everflex, Red

Part No.	Description	No. Off	List Price	Your Price
----------	-------------	---------	------------	------------

TOPS MADE FROM EVERFLEX MATERIAL,

a very high-quality topping material from England, please specify colour desired, black, white, khaki tan, caramel tan, dark brown, cream, red, blue, green, maroon, or grey

RB2219/EV	Deluxe Top , TR250; fixed rear window as original; correct reflective striping for TR250	1		
RB2219/AEV	Deluxe Top , TR250; zip-out rear window; correct reflective striping for TR250	1		
RB2220/EV	Deluxe Top , TR6; zip-out rear window as original; correct reflective striping for TR6	1		

TOPS MADE FROM SUNFAST CANVAS

MATERIAL, a modern canvas material layered with rubber and cotton backing, please specify colour desired, black, blue, tan, brown, grey, redberry, or true burgundy

RB2219/SF	Deluxe Top , TR250; fixed rear window as original; correct reflective striping for TR250	1		
RB2219/ASF	Deluxe Top , TR250; zip-out rear window; correct reflective striping for TR250	1		
RB2220/SF	Deluxe Top , TR6; zip-out rear window as original; correct reflective striping for TR6	1		

WEATHER EQUIPMENT

ROBBINS CONVERTIBLE TOPS WITHOUT REFLECTIVE STRIPES, TR250, TR6

“Also Available in Three Materials and Many Colours”

The tops without reflective stripes cost a little less than tops with them, but the quality is just as good. Maybe you don't like reflective striping. Actually, the stripes were not used in most markets other than the U.S. for TR5 and TR6 models. The tops listed here do include zip-out windows.

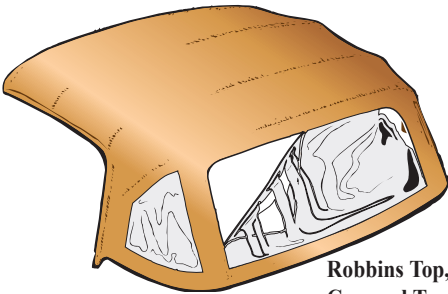

Robbins Top,
Caramel Tan

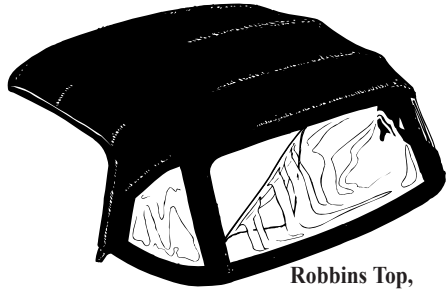

Robbins Top,
Black

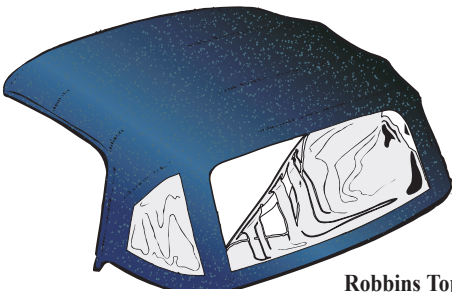

Robbins Top,
Sunfast Canvas, Blue

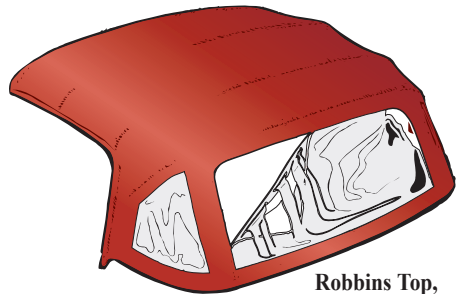

Robbins Top,
Everflex, Red

Part No.	Description	No. Off	List Price	Your Price
----------	-------------	---------	------------	------------

TOPS MADE FROM ROBBINS MATERIAL;

please specify colour desired, black, white, khaki tan, or caramel tan

RB2207/A	Convertible Top , comes with zip-out rear window, no reflective stripes	1		
----------	--	---	--	--

TOPS MADE FROM EVERFLEX MATERIAL,

a very high-quality topping material from England; please specify colour desired, black, white, khaki tan, caramel tan, dark brown, cream, red, blue, green, maroon, or grey

RB2207/AEV	Convertible Top , comes with zip-out rear window, no reflective stripes	1		
------------	--	---	--	--

TOPS MADE FROM SUNFAST CANVAS

MATERIAL, a modern canvas material layered with rubber and cotton backing; please specify colour desired, black, blue, tan, brown, grey, redberry, or true burgundy

RB2207/ASF	Convertible Top , comes with zip-out rear window, no reflective stripes	1		
------------	--	---	--	--

WEATHER EQUIPMENT

OUR LEAST EXPENSIVE ROBBINS TOPS, TR250, TR6

“Choice of Four Colours in Standard Robbins Material”

Our least-expensive top is manufactured with the same fine workmanship as the other tops listed in the sections above, but it does not include a zip-out rear window or reflective stripes. Otherwise, it is just the same...

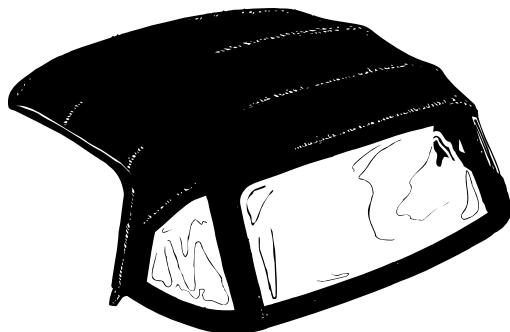

Economy Top, Black

Part No.	Description	No.Off	List Price	Your Price
----------	-------------	--------	------------	------------

TOPS MADE FROM ROBBINS

MATERIAL; please specify colour desired, black, white, khaki tan, or caramel tan

RB2207

Convertible Top; without reflective stripes, without zip-out rear window

1



Newly Restored TR6 with Robbins Top at TRF



TR6 Ready for Top Installation

WEATHER EQUIPMENT

SPECIAL CONVERTIBLE TOP, TR250, TR6

“High-Quality Grained Black Vinyl with Black Lining and Reflective Stripes”

We do not have anything to list in this section as we go to press, but we will be working to find a suitable replacement for our very best material which was discontinued recently. For a full discussion of this problem, please see page 279. When the material we are looking for is found, this section will be updated on the web site, and prices will appear. In the mean time, I have to list these tops as **NLS** (No Longer Supplied).



Part No.	Description	No. Off	List Price	Your Price
	CONVERTIBLE TOPS , high-quality black material; suitable vinyl grain and black backing			
HP2219	Convertible Top , TR250 reflective stripes, fixed rear window	1		
HP2219/A	Convertible Top , TR250 reflective stripes, zip-out rear window	1		
HP2220	Convertible Top , TR6 reflective stripes, zip-out rear window	1		

WEBBING STRIPS FOR CONVERTIBLE TOP FRAMES, TR250, TR6

“TRF Purchases Top-Frame Webbings from the Original Manufacturer in England”

The Roadster Factory has managed to maintain supply of top frame webbings in the original factory pattern. I used to joke that this means that you don't have to use lawn chair webbings anymore. This is a reference to a common practice from when I was younger, and British car enthusiasts often had to improvise. Nowadays, readers may not know what a lawn chair webbing might

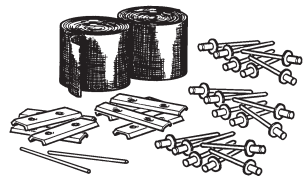

Part No.	Description	No. Off	List Price	Your Price
RFK495	COMPLETE KIT ; includes webbings, plates, rivets, and pins; everything you need!	1		
631970	Webbing Strip , convertible top frame; original-equipment pattern	2		
602030	Plate , securing webbings to frame	8		
571097	Pin , securing webbings to rear stiffening angle	2		
554407	Pop Rivet , securing plates to frame	16		

WEATHER EQUIPMENT

LATCHING HANDLES FOR CONVERTIBLE TOP FRAMES,
TR250, TR6*“Read Listings Carefully If You Are
Purchasing Individual Components”*

Damaged latching components can make it unpleasant to put your top up and down. All latch components are now available, including complete assemblies. If you are replacing the screws which secure the handles to the latching pins but not replacing the pins, you will want to purchase the screw kit, as some pins had metric threads and some had English threads.

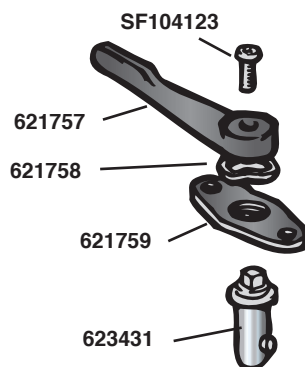

Part No.	Description	No. Off	List Price	Your Price
RFK1042	LATCHING HANDLE KIT; fits either side; complete latch assembly	2		
623431	Pin, latching	2		
621759	Escutcheon, latch	2		
621757	Handle, latching	2		
621758	Washer, waved, between handles and escutcheons	2		
SF104123	Screw, securing handles to latching pins	2		
RFK1646	HARDWARE, securing latch assemblies to top frame	1		
509199	Screw, set	4		
WP5	Washer, plain	4		
WN705	Washer, shakeproof	4		
HN2005	Nut, hex	4		
ADDITIONAL LISTING				
RFK394	Screw Kit, securing latching handles to latching pins; includes metric and English screws for two latches	1		

MOUNTING HARDWARE FOR CONVERTIBLE TOP FRAME,
TR250, TR6*“Pointed Screws Still Available”*

Triumphs originally used a lot of pointed screws, especially earlier models, and most of them were still available in Triumph packaging when TRF was founded in 1978. Not so today, and pointed screws are hard to find. This is one that is still available because there is good demand for it.



Part No.	Description	No. Off	List Price	Your Price
516158/P	Screw, securing top frame to car body behind doors; screw driver slot and pointed end, as original	6		

WEATHER EQUIPMENT

RUBBER SEALS AND CHANNELS FOR CONVERTIBLE TOP FRAMES, TR250, TR6

“Everything Available to Restore Your Top Frame...”

Receiving correct rubber seals and metal channels, along with all correct hardware just by ordering a couple of part numbers makes restoring your top frame an easier task. Whenever you replace your convertible top, it makes sense to put the frame, channels, and seals back into perfect condition, as the job is much easier when the frame can be completely stripped. A TR250 or TR6 is warm and dry in cold and rain if the seals are kept in top condition.

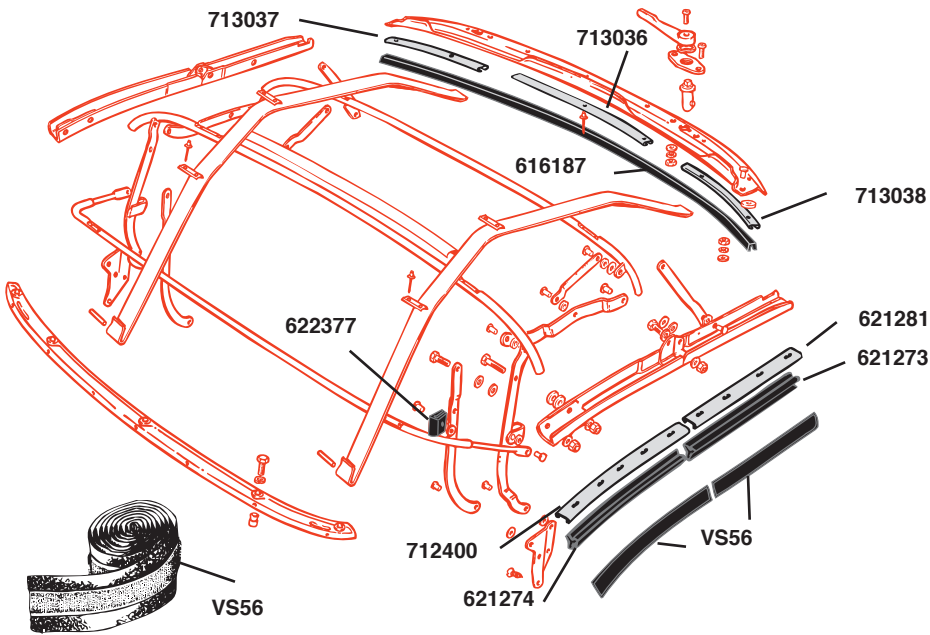

Part No.	Description	No. Off	List Price	Your Price
----------	-------------	---------	------------	------------

RUBBER SEALS

616187	Rubber Seal , front of top frame to top of windscreen	1		
621273	Rubber Seal , roof side, front	2		
621274	Rubber Seal , roof side, rear	2		
VS56	Velcro Strip Kit ; velcro sewn to strips of Everflex for recovering sides of soft top frame; kit includes all four sections required	1		

RUBBER BUFFER, convertible top frame, secured to frame link with a rivet and a washer

622377	Buffer , rubber, on main links	2		
--------	---------------------------------------	---	--	--

CHANNELS, retaining rubber seals

713036	Channel , center, retaining front seal	1		
713037	Channel , LH, retaining front seal	1		
713038	Channel , RH, retaining front seal	1		
621281	Channel , alloy, roof side, front	2		
712400	Channel , alloy, roof side, rear	2		

Section Continues ▶▶

WEATHER EQUIPMENT

RUBBER SEALS AND CHANNELS FOR CONVERTIBLE TOP FRAMES, TR250, TR6—Continued

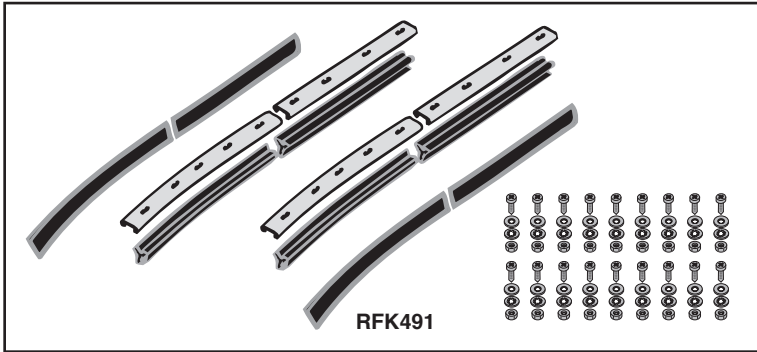
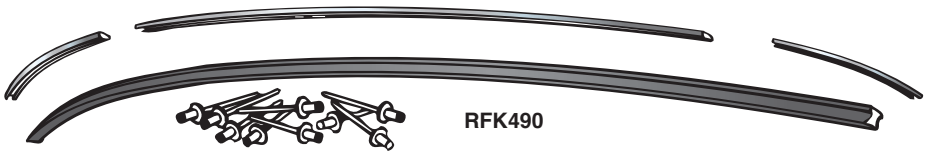

Part No.	Description	No. Off	List Price	Your Price
HANDY SEAL AND CHANNEL KITS;				
	includes seals, plus channels, plus all related hardware			
RFK490	Sealing Kit , front rail of soft top frame; includes rubber seal, plus three steel channels and pop rivets to secure channels to top frame	1		
RFK491	Sealing Kit , roof side rails; includes front and rear seals and Velcro strips, plus alloy channels and hardware kit for securing channels to soft top frame	1		

REAR MOUNTING RAIL FOR CONVERTIBLE TOP, TR250, TR6

“Secures Soft Top to Rear Deck Behind Cockpit”

The rear stiffening rail which mounts the back of the soft top to the rear deck may be badly rusted or missing from your car. You can buy this part new along with correct mounting hardware...



Part No.	Description	No. Off	List Price	Your Price
812832	Stiffening Rail , mounting rear of soft top to rear deck	1		
RFK493	Hardware Kit , securing stiffening rail to rear deck; includes five set screws and five lock washers	1		

WEATHER EQUIPMENT

ORIGINAL PLASTIC SNAPS FOR YOUR CONVERTIBLE TOP, TR250, TR6

“Choose Black or White Snaps and Studs as Original on These Models”

Both TR250 and TR6 convertible tops came with plastic snaps. Plastic snap studs were fitted to the car body as well. At the time of production, many of us thought that plastic components were a cheap and nasty way to go. Shame on Triumph for not providing information at the time that the plastic snaps are actually better. Even the dealers would often replace plastic snaps with metal ones when a customer complained. This writer actually fitted TR3-type lift-the-dot snaps to his TR6 at one time. The fact is that the plastic snaps are tighter and less noisy than the old metal snaps. They are also what Triumph supplied originally, and that alone is a reason for keeping them. For all of these reasons, TRF works to keep all of the original snap components in stock in both black and white. We also offer handy kits that include all components under just one part number.



RFT149

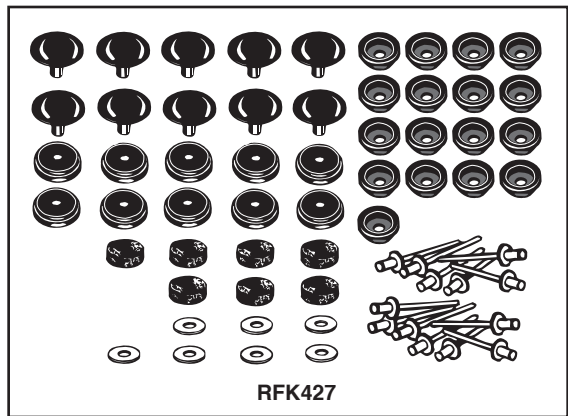

RFK427

Part No.	Description	No. Off	List Price	Your Price
RFK427	BLACK FASTENER KIT; for installing TR250 or TR6 tops; includes black plastic snaps and studs, plus rivets, washers, and pads; buy this kit if you prefer to use original snaps on your new convertible top...	1		
713511	Stud, black plastic; male part riveted to the body	17		
554407	Pop Rivet, securing studs to car	17		
713501	Socket, black plastic; female snap component	10		
ZKC751	Button, black plastic; outer snap component	10		
WP2	Washer, plain, reinforcing rivets on rear stiffening angle	7		
631771	Pad, cemented on rivet ends on underside of rear stiffening angle to protect body paint	7		
RFT149	Tool, snap installation, metal, secures sockets and buttons to tops and tonneau covers without leaving tool marks, not included in snap kits	A/R		

Section Continues ►►

WEATHER EQUIPMENT

ORIGINAL PLASTIC SNAPS FOR YOUR CONVERTIBLE TOP, TR250, TR6—Continued



RFT149

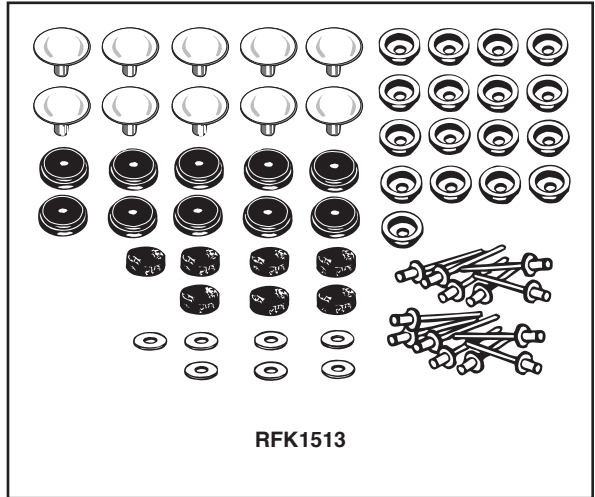

RFK1513

Part No.	Description	No. Off	List Price	Your Price
RFK1513	WHITE FASTENER KIT; for installing TR250 or TR6 tops; includes white plastic snap buttons and studs, plus black snap sockets, rivets, washers, and pads; buy this kit if you prefer to use original snaps on your new convertible top...	1		
713519	Stud, white plastic; male part riveted to the body	17		
554407	Pop Rivet, securing studs to car	17		
713501	Socket, black plastic; female snap component	10		
713499	Button, white plastic; outer snap component	10		
631771	Pad, cemented on rivet ends on underside of rear stiffening angle to protect body paint	7		
WP2	Washer, plain, reinforcing rivets on rear stiffening angle	7		
RFT149	Tool, snap installation, metal, secures sockets and buttons to tops and tonneau covers without leaving tool marks, not included in snap kits	A/R		

WEATHER EQUIPMENT

CONVERTIBLE TOP BOOTS, AKA HOOD STOWAGE COVERS, TR250, TR6

“Four Material Choices Including Sunfast Canvas”

If your original boot has seen better days or if it is missing altogether, you can purchase any of the ones listed here with confidence. TRF’s boots are manufactured by The Magic Carpet Factory, and quality is excellent in any of the material choices offered. Note that custom details are available, sometimes at an additional charge. Items such as piping colour choices or vinyl piping on a Sunfast canvas boot are possible, as most convertible top boots are made to order, usually within two or three weeks of receiving the order. Availability of exotic materials may sometimes lengthen the time required for delivery.

Convertible top boots were originally made in outdoor material to match interior vinyl colours. Regrettably, none of these materials is available today, although some of the materials used by The Magic Carpet Factory come very close. Boots are offered in Robbins top material which comes in four basic colours to match Robbins tops. Boots are also offered in British Everflex material, which is a very high quality outdoor material, and colours such as red are a good match for a Matador Red interior. Caramel tan in either Robbins material or in Everflex also makes a good match for Light Tan used for TR250 and very early TR6 interiors. Sunfast canvas is another option, in which case a Sunfast top would be the likely thing to match. If you have your heart set on matching an interior colour such as New Tan or Shadow Blue, then making your boot from interior vinyl is the best choice available. Interior vinyl may not be as durable as the other materials in this application, but The Magic Carpet Factory reinforces it underneath for the best possible result.

The Magic Carpet Factory’s patterns are carefully worked out, and the finished products are very nice indeed. Many hundreds have been sold over the past fifteen years. Material and colour samples are available for free upon request. Please specify materials and colours desired when requesting material samples.

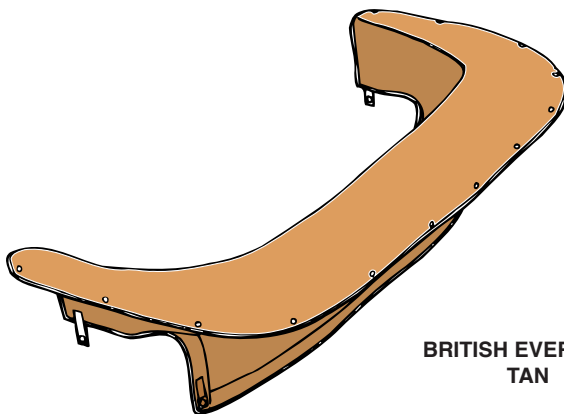

BRITISH EVERFLEX,
TAN

Section Continues ►►

WEATHER EQUIPMENT

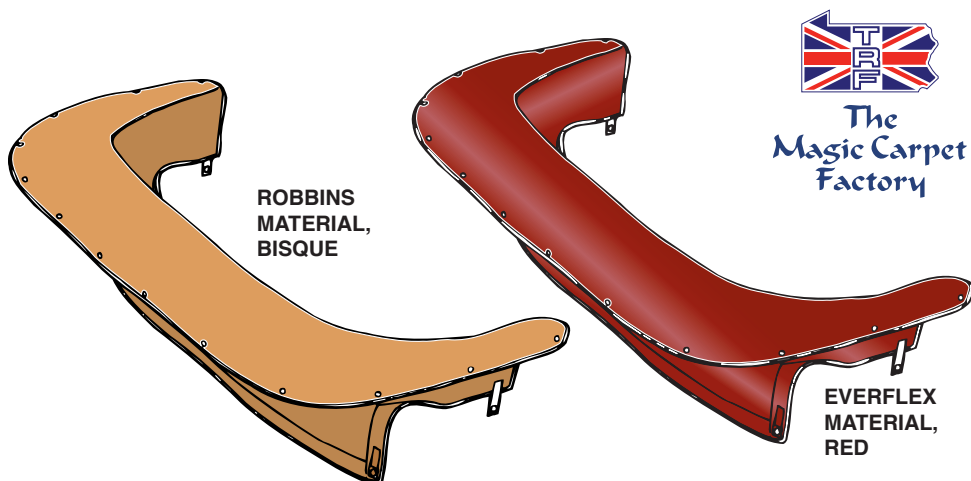
**CONVERTIBLE TOP BOOTS, AKA HOOD STOWAGE COVERS,
TR250, TR6—Continued**

Part No.	Description	No.Off	List Price	Your Price
----------	-------------	--------	------------	------------

CONVERTIBLE TOP BOOTS, TR250;

note that white piping will be used on all colours unless another colour is specified

713461	Convertible Top Boot , TR250, made from Robbins material; please specify colour desired, black, white, khaki tan, or caramel tan	1		
713461/EV	Convertible Top Boot , TR250, made from British Everflex material; please specify colour desired, black, white, khaki tan, caramel tan, dark brown, cream, red, blue, green, maroon, or grey	1		
713461/IV*	Convertible Top Boot , TR250, made from interior vinyl to match TRF's interior panels and seats, please specify colour desired, bright red, midnight blue, or shadow blue	1		
713461/SF	Convertible Top Boot , TR250, made from Sunfast canvas material; please specify colour desired, black, blue, tan, brown, grey, redberry, or true burgundy	1		

* Please Note that interior vinyl will not be as durable as convertible top materials for convertible top boots, although The Magic Carpet Factory reinforces them inside with stronger material. This is offered for those who want a boot to match their interiors. For early black interiors, we would recommend black Everflex instead, and for Triumph light tan interiors, we would recommend Everflex in khaki tan instead.

Section Continues ►►

WEATHER EQUIPMENT

CONVERTIBLE TOP BOOTS, AKA HOOD STOWAGE COVERS, TR250, TR6—Continued

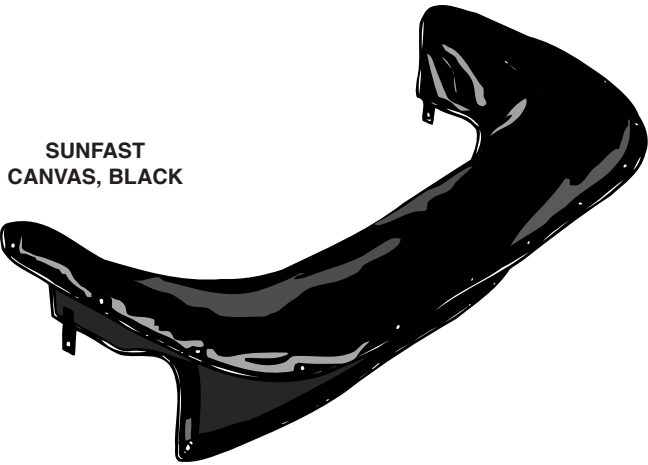

Part No.	Description	No.Off	List Price	Your Price
	CONVERTIBLE TOP BOOTS, TR6; note that matching piping will be used on all colours as original, unless another colour is specified			
726211	Convertible Top Boot, TR6, made from Robbins material; please specify colour desired, black, white, khaki tan, or caramel tan	1		
726211/EV	Convertible Top Boot, TR6, made from British Everflex material; please specify colour desired, black, white, khaki tan, caramel tan, dark brown, cream, red, blue, green, maroon, or grey	1		
726211/IV*	Convertible Top Boot, TR6, made from interior vinyl to match TRF's interior panels and seats, please specify colour desired, shadow blue, new tan, chestnut, beige, and possibly black if the late "longhorn" grain is desired	1		
726211/SF	Convertible Top Boot, TR6, made from Sunfast canvas material; please specify colour desired, black, blue, tan, brown, grey, redberry, or true burgundy	1		

* Please Note that interior vinyl will not be as durable as convertible top materials for convertible top boots, although The Magic Carpet Factory reinforces them inside with stronger material. This is offered for those who want a boot to match their interior colours as was original. For early black interiors, we would recommend black Everflex instead, and for Triumph light tan interiors, we would recommend Everflex in khaki tan instead. Red Everflex is also a good match for matador red.

WEATHER EQUIPMENT

ORIGINAL PLASTIC SNAPS FOR YOUR TONNEAU COVER, TR250, TR6

“Both Black and White Plastic Snaps Now Available”

New tonneau covers do not come with original snaps, and TRF, therefore, lists separate snap kits in case customers prefer these. You can install these on a new tonneau cover, or you can replace broken snaps on a well used original tonneau that may have come with your car. In addition to the black plastic snaps available from most sources, TRF has manufactured the white snaps used on TR250 and early TR6 models with white tops or tonneau covers. Note that only complete snap kits are listed in this section, but individual snap components may be purchased separately as listed on pages 288-289 along with snap kits for convertible top.

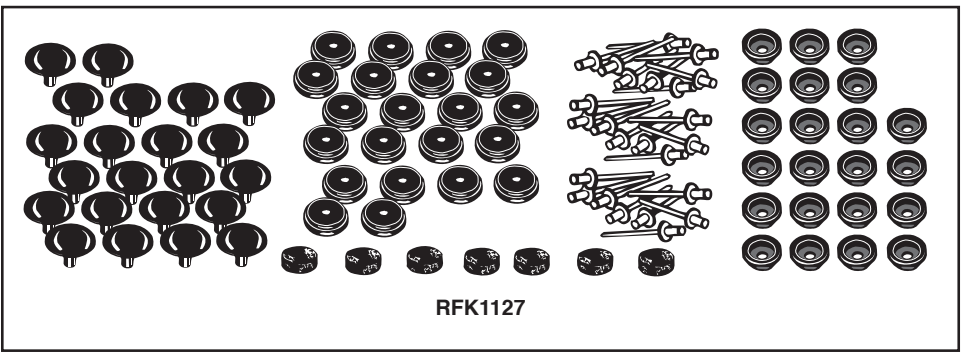

RFK1127

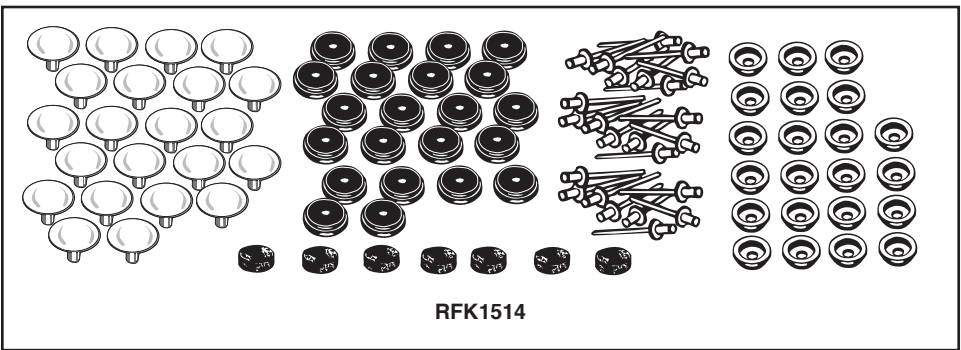

RFK1514

Part No.	Description	No. Off	List Price	Your Price
----------	-------------	---------	------------	------------

RFK1127	BLACK FASTENER KIT; for installing TR250 or TR6 tonneau covers; includes black plastic snaps and studs, plus rivets, washers, and pads; buy this kit if you prefer to use original plastic snaps on your new tonneau cover	1		
---------	---	---	--	--

RFK1514	WHITE FASTENER KIT; for installing TR250 or TR6 tonneau covers; includes white plastic snap buttons and studs, plus black snap sockets, rivets, washers, and pads; buy this kit if you prefer to use original plastic snaps on your new tonneau cover	1		
---------	--	---	--	--

WEATHER EQUIPMENT

ROBBINS BRAND TONNEAU COVERS, TR250, TR6

“Choose Robbins Own Material, British Everflex, or Sunfast Canvas”

Tonneau covers are great for when you are driving around by yourself. Just unzip the driver’s side, and zip it back up when you park on the street. The tonneau cover protects your car’s interior from sunlight and from sudden downpours when it is parked. A sports car looks even more sporty when a tonneau cover is fitted. With British Everflex vinyl and Sunfast canvas added to our selection, you have some very interesting choices if you buy a tonneau cover this year...

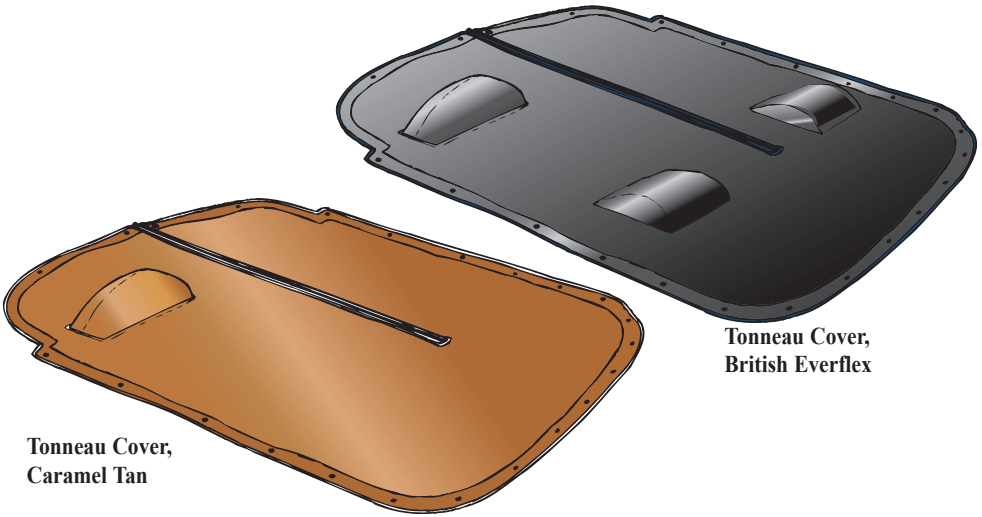

Tonneau Cover, Caramel Tan

Tonneau Cover, British Everflex

Part No.	Description	No. Off	List Price	Your Price
	TONNEAU COVERS, TR250 models			
RBTC1207	Tonneau Cover, TR250 , made from Robbins top material; please specify colour desired, black, white, khaki tan, or caramel tan	1		
RBTC1207/EV	Tonneau Cover, TR250 , made from British Everflex material; please specify colour desired, black, white, khaki tan, caramel tan, dark brown, cream, red, blue, green, maroon, or grey	1		
RBTC1207/SF	Tonneau Cover, TR250 , made from Sunfast canvas material; please specify colour desired, black, blue, tan, brown, grey, redberry, or true burgundy	1		

Section Continues ▶▶

WEATHER EQUIPMENT

ROBBINS BRAND TONNEAU COVERS, TR250, TR6—Continued

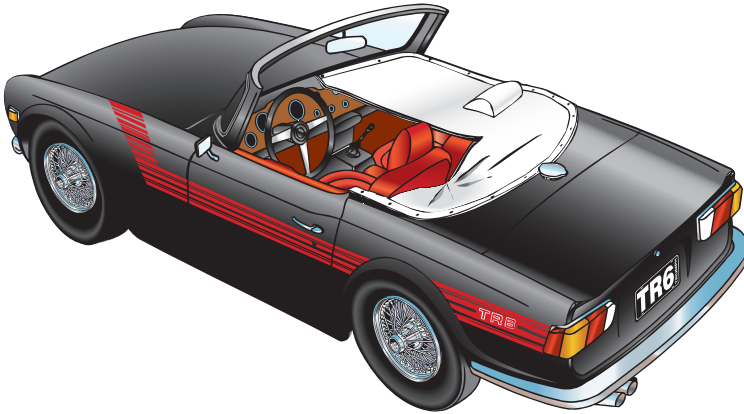

Part No.	Description	No. Off	List Price	Your Price
	TONNEAU COVERS, TR6 models, with folding head rests on seats, 1969 only, maybe very early 1970			
RBTC1207	Tonneau Cover, TR6, 1969, made from Robbins top material; please specify colour desired, black, white, khaki tan, or caramel tan	1		
RBTC1207/EV	Tonneau Cover, TR6, 1969, made from British Everflex material; please specify colour desired, black, white, khaki tan, caramel tan, dark brown, cream, red, blue, green, maroon, or grey	1		
RBTC1207/SF	Tonneau Cover, TR6, 1969, made from Sunfast canvas material; please specify colour desired, black, blue, tan, brown, grey, redberry, or true burgundy	1		
	TONNEAU COVERS, TR6, 1970-76 models; tonneau covers include pockets for head rests on seat backs			
RBTCH1207/A	Tonneau Cover, TR6, 1970-76, made from Robbins top material; please specify colour desired, black, white, khaki tan, or caramel tan	1		
RBTCH1207/AEV	Tonneau Cover, TR6, 1970-76, made from British Everflex material; please specify colour desired, black, white, khaki tan, caramel tan, dark brown, cream, red, blue, green, maroon, or grey	1		
RBTCH1207/ASF	Tonneau Cover, TR6, 1970-76, made from Sunfast canvas material; please specify colour desired, black, blue, tan, brown, grey, redberry, or true burgundy	1		

WEATHER EQUIPMENT

FACTORY HARD TOP, TR250

“Seals for Hard Top Are Listed on Pages 204-205”

The TR250 hard top is often referred to as a “Surrey Top,” but correctly speaking, this term applies only to the soft top and frame assembly which may be substituted for the removable hard top center section. The number of smaller components listed here in this Glove Box Catalogue is limited. If a finer breakdown is desired, please refer to TRF’s TR250 Spare Parts Catalogue (Red), available for purchase.

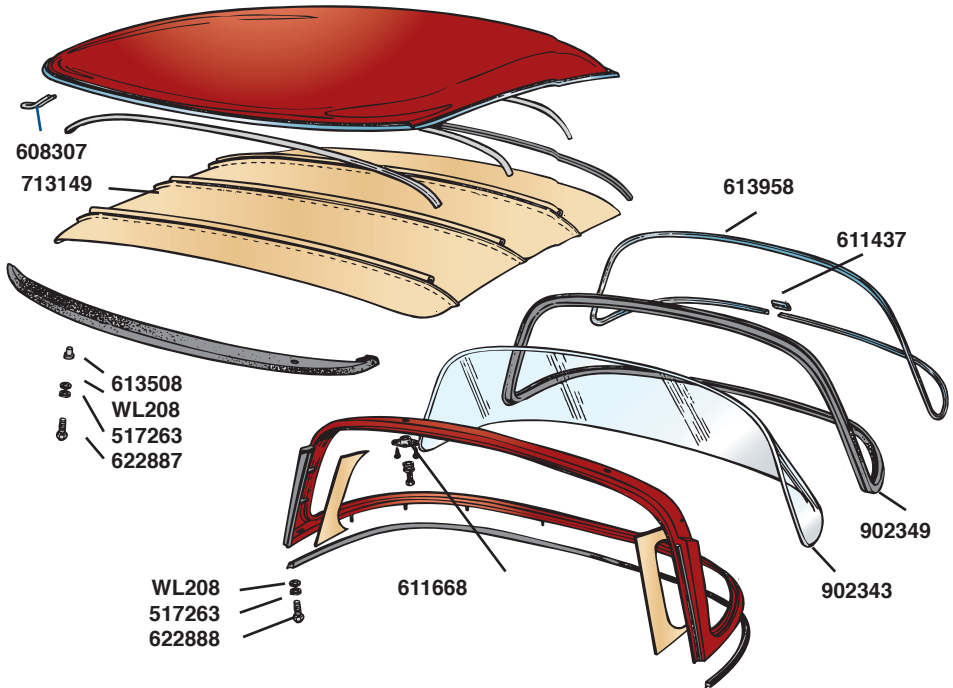

Part No.	Description	No. Off	List Price	Your Price
----------	-------------	---------	------------	------------

REAR WINDOW GLASS AND SEALS

902343	Glass , clear	1		
CRATE50	Crating Charge on Rear Window Glass	1		
902349	Seal , rubber, around glass	1		
613958	Trim Strip , chromed plastic, fitted around glass	1		
	JOINT CLIPS , for trim strip, original			
	chromed metal clips			
611437	Clip , joint, 1-1/2 inch length	1		
611437/175	Clip , joint, 1-3/4 inch length	1		
611437/200	Clip , joint, 2-inch length	1		
RFK1617	HARDWARE KIT , securing hard top to	1		
	windscreen and to rear window frame			
622887	Bolt , domed, securing hard top to windscreen	2		
	frame, black			
613508	Tube , distance, hard top to windscreen frame	2		
WL208	Washer , lock	2		
517263	Washer , plain	2		
622888	Bolt , domed, securing hard top to rear window	2		
	frame, black; bolt is too long, must be shortened			
WL208	Washer , lock, zinc	2		
517263	Washer , plain, black	2		

WEATHER EQUIPMENT

FACTORY HARD TOP, TR250—Continued

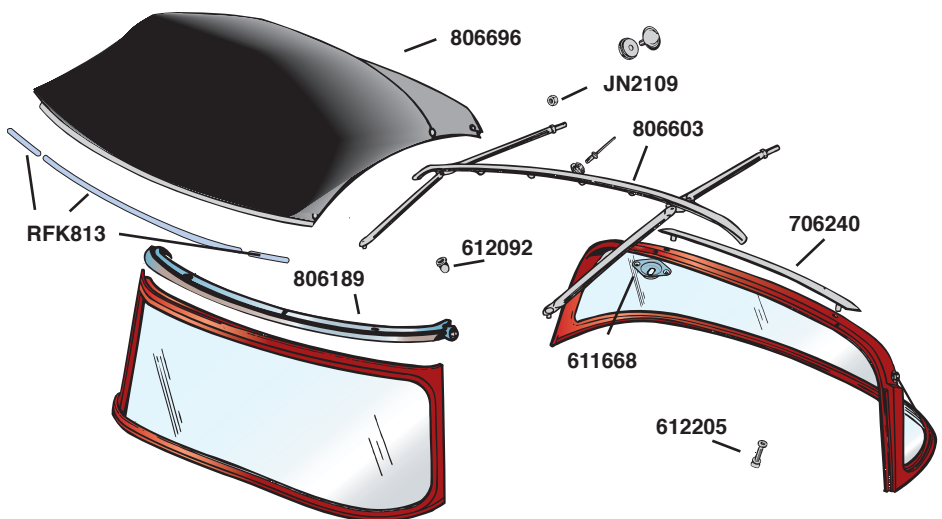

Part No.	Description	No. Off	List Price	Your Price
	ESCUTCHEONS , fitted to rear window frame; apologies for not having hardware yet			
611668	Escutcheon , fitted to rear window frame, around bolt holes	2		
	CHROMED CAPPING , windscreen top, required to fit Surrey soft top section			
806189	Capping , chromed, TR4 type	1		
554407	Pop Rivet , securing capping	9		
	HARD TOP HEADLINER , manufactured by The Magic Carpet Factory			
713149	Headliner Kit ; white material similar to original; ready to install with sewn in sleeves for listing rails; includes matching material for covering rear window frame; now includes covered metal trim panels rear door posts	1		
608307	Clip , end, headliner support rods	6		
	SURREY SOFT TOP DETAILS			
806696	Soft Top Cover Assembly , black	1		
806697	Soft Top Cover Assembly , white	1		
RFK813	Stiffener Kit ; three steel strips which fit into front seam of soft top cover	1		
806603	H-Frame , for soft top	1		
612092	Rubber Cap , fitted to front arms of H-frame	2		
JN2109	Jam Nut , adjusting tension of H-frame; fitted to threads on rear arms	2		
706240	Retainer Bar Assembly , securing soft top cover to rear window frame	1		
612205	Thumb Screw , securing retainer bar to rear window frame	2		

WEATHER EQUIPMENT

FACTORY HARD TOP, TR6

“Hard Top Seals Are Listed on Page 206, and Chromed Trim on Page 218”

The TR6 factory hard top was designed at Triumph in England to go on the body designed by Karmann in Germany. I think that we will all agree that it is a harmonious design. In fact, the hard top makes the TR6 a different car, a real weather-tight coupe with a more rigid body/frame assembly. You may be lucky enough to own a car that came from the factory with a hard top, or you may find a used one to fix up for your car. The used market on hard tops is very lively, and it is not unusual for used hard tops in good condition to sell for more than \$1,000. If you have found a used hard top, it may be missing some components. The good news is that most of these are available...

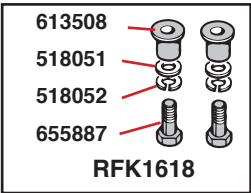
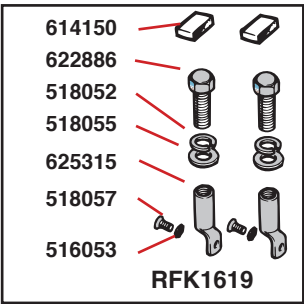
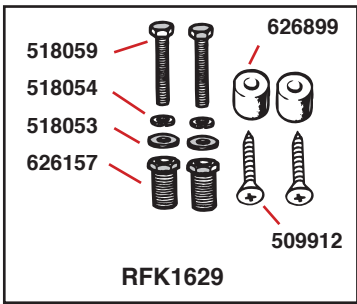
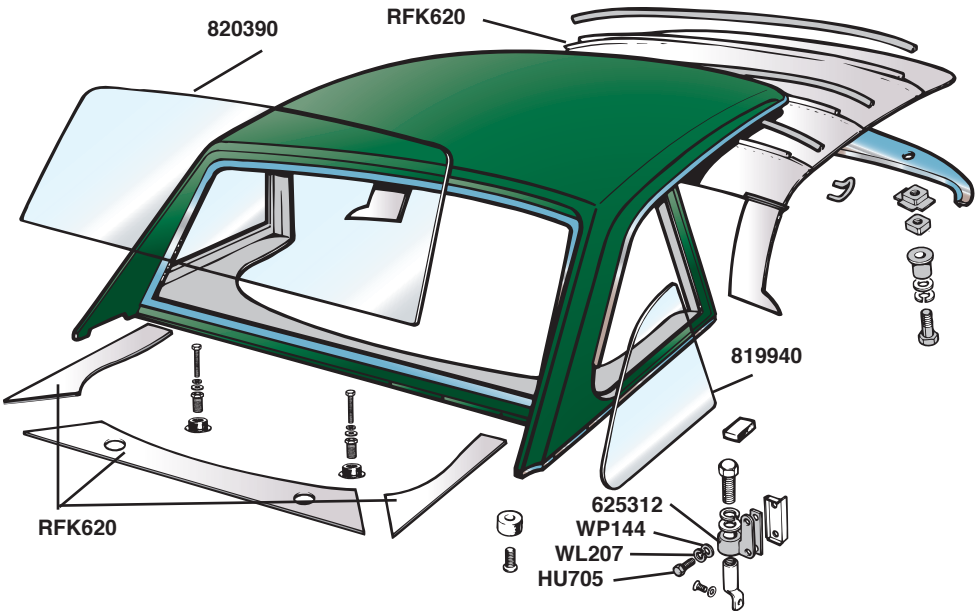

Part No.	Description	No. Off	List Price	Your Price
----------	-------------	---------	------------	------------

HARD TOP GLASS, rear window and quarter windows; seals for glass are found on page 206.

820390	Glass , rear window	1		
819940	Glass , rear quarter windows	2		
CRATE35	Crating Charge on Rear Window Glass	1		

Section Continues ►►

WEATHER EQUIPMENT

FACTORY HARD TOP, TR6—Continued

Part No.	Description	No. Off	List Price	Your Price
	HARD TOP HEADLINERS; manufactured by The Magic Carpet Factory; material very similar to original; ready to install with sewn-in sleeves for listing rails; includes three trim panels for rear shelf area			
RFK620/WHT	Headliner Kit , off-white material	1		
RFK619/BLK	Headliner Kit , black material	1		
608307	Clip , end, headliner support rods	6		
	INSTALLATION COMPONENTS			
RFK1618	HARDWARE KIT , securing hard top to windscreen frame; paint hardware black if necessary	1		
613508	Tube , distance	2		
WP125	Washer , plain	2		
WL208	Washer , lock	2		
622887	Bolt , domed head, black	2		
RFK1619	HARDWARE KIT , securing hard top to soft top frame mounting area; paint hardware black if necessary	1		
614150	Block , rubber	2		
625315	Tie-bar , side mountings	2		
	HARDWARE , securing tie-bars to inner rear quarters			
517148	Screw , set	2		
WP7	Washer , plain	2		
	HARDWARE , securing hard top to tie-bars			
622886	Bolt , dome head, black	2		
WL208	Washer , lock	2		
WP139	Washer , plain	2		
	BRACKETS , bolted to hard top to secure it to tie-bars listed above; these are not included in the kit listed above, as they are generally found on used hard tops			
625311	Bracket , mounting, LH	1		
625312	Bracket , mounting, RH	1		
	HARDWARE , securing brackets to hard top shell			
HU705	Screw , set	4		
WL207	Washer , lock	4		
WP144	Washer , plain	4		
RFK1629	HARDWARE KIT , securing top to rear deck	1		
626899	Buffer , rubber, hard top to rear deck	2		
509912	Screw , set, securing buffers to hard top	2		
626157	Fitting , adjustment	2		
HU712	Screw , set	2		
WL207	Washer , lock	2		
WP7	Washer , plain	2		
RFP290	Fitting Instructions; instructions included by the factory in every hard top kit; reprint	1		

WEATHER EQUIPMENT

COVERCRAFT- BRAND CAR COVERS, TR250, TR6

“Compare to Weather-Shield Car Covers Listed in the Next Section”

The Roadster Factory offers a range of car covers by Covercraft. The ones listed in this section are the traditional materials, inexpensive poly-cotton dust covers, flannel-lined twill car covers for indoors or for outdoors in dry weather, and Technalon car covers for use indoors or outdoors in any weather. “Custom Fit” will provide a better fit to the contours of the car, and “Universal Fit” is a looser fit, as it is made to fit a number of different models of similar size. Most custom fit car covers are made to order, but delivery is still pretty fast.



Part No.	Description	No. Off	List Price	Your Price
POLY-COTTON DUST COVERS; use indoors as a dust cover or outside in dry weather for sun protection				
TRFCC401	Car Cover , poly-cotton, universal fit; TR250, TR6 1969-1973	1		
TRFCC403	Car-Cover , poly-cotton, universal fit; TR6 1974-76	1		
LUXURIOUS FLANNEL-LINED CAR COVERS; use indoors as a dust cover or outdoors in dry weather for sun protection				
TRFCC102	Car Cover , flannel-lined, custom fitted, TR250, TR6 1968-73	1		
TRFCC103	Car Cover , flannel-lined, custom fitted, TR6, 1974-76	1		
ALL-WEATHER TECHNALON CAR COVERS; use indoors or out in all weathers				
TRFCC410	Car Cover , Technalon, universal fit, all TR250, TR6	1		
TRFCC111	Car Cover , Technalon, custom fit, TR250, TR6, 1968-73	1		
TRFCC112	Car Cover , Technalon, custom fit, TR6, 1974-76	1		
CAR COVER ACCESSORIES				
TRFCC501	Storage Bag , for storing car cover neatly; washable drawstring bag	1		
TRFCC601	Cable and Lock Set , to insure that your car cover is still there the next morning	1		

WEATHER EQUIPMENT

“WEATHER SHIELD” CAR COVERS IN BRIGHT COLOURS, TR250, TR6

“Available Colours Are Racing Green, Red, Black, Yellow, Dark Blue, Light Blue, Grey, or British Tan”

I was excited the first time I listed these brightly-coloured car covers, as I picture finding my car in a parking lot at a car show much easier if it has a Bright Yellow car cover. The material used is also very highly rated for indoor use, outdoor use, all weather, resistance to all of the elements, breathability, small storage, and wash/dry at home. Quality of these car covers manufactured by Covercraft is excellent, and they are available only in “Custom Fit,” which means that they are designed for the contours of each particular model, although the same one will fit TR250 and early TR6(!). Because of the large number of colours, these car covers are made to order, and delivery time will be approximately four weeks.



Light Blue



Bright Yellow



Bright Red



Dark Blue

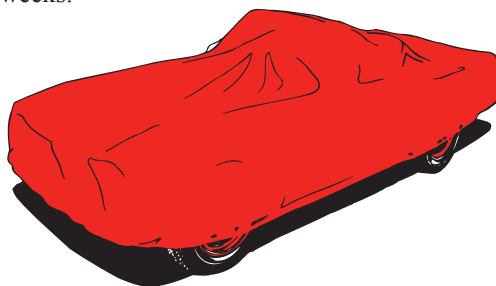

British Tan



Grey



British Racing Green



Black

Part No.	Description	No.Off	List Price	Your Price
----------	-------------	--------	------------	------------

“WEATHER SHIELD” CAR COVERS,

from Covercraft, TR250, TR6, 1968-73

CCC102/BRG	Car Cover , British racing green	1		
CCC102/RED	Car Cover , bright red	1		
CCC102/BLK	Car Cover , black	1		
CCC102/YEL	Car Cover , bright yellow	1		
CCC102/DBL	Car Cover , dark blue	1		
CCC102/LBL	Car Cover , light blue	1		
CCC102/GRY	Car Cover , grey	1		
CCC102/BTN	Car Cover , British tan	1		

“WEATHER SHIELD” CAR COVERS,

from Covercraft, TR6, 1974-76

CCC103/BRG	Car Cover , British racing green	1		
CCC103/RED	Car Cover , bright red	1		
CCC103/BLK	Car Cover , black	1		
CCC103/YEL	Car Cover , bright yellow	1		
CCC103/DBL	Car Cover , dark blue	1		
CCC103/LBL	Car Cover , light blue	1		
CCC103/GRY	Car Cover , grey	1		
CCC103/BTN	Car Cover , British tan	1		

P.S. Colour blocks were electronically scanned, and may not accurately represent the colours available.