

RUBBER BODY SEALS AND GASKETS

“TRF Has a Wide Range of Rubber Body Seals to Bring Your Car Back to New”

BONNET SEALS

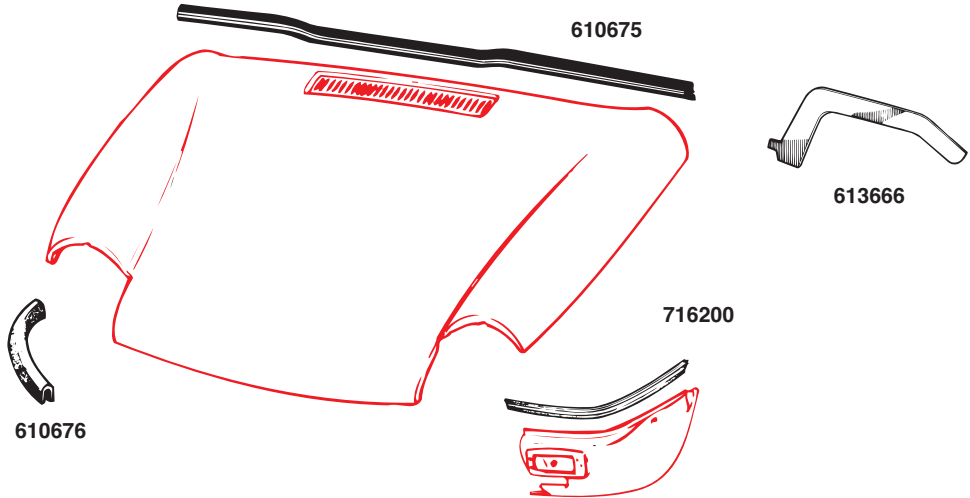

Part No.	Description	No. Off
610675	Rubber Seal , fitted to edge of cowl, all Spitfire	1
613666	Rubber Seal , front wheel arch to body, all Spitfire	2
606389	Clip , securing wheel arch seals	18
610676	Rubber Seal , bonnet to front valance	2
716200	Rubber Seal , bonnet to quarter valance panels, Spitfire mk.4, 1500	2

TRUNK LID SEALS

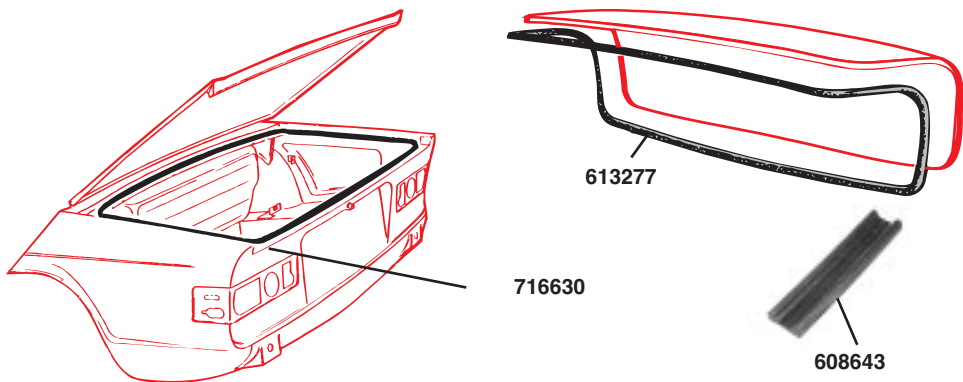

Part No.	Description	No. Off
613277	Rubber Trunk Lid Seal , Spitfire mks.1, 2, 3	1
608643	Rubber Packing ; sponge rubber strips between reinforcement tubes and underside of trunk lid, Spitfire mks.1, 2, 3	6
716630	Trunk Lid Seal , Spitfire mk.4, 1500	1

RUBBER BODY SEALS AND GASKETS

DOOR SEALS—BRISTLEFLEX FUZZY DOOR SEALS

These are the new high-quality seals sold by TRF for the last few years. The cross-section of these seals is the closest match to original that you will find for a perfect fit and an original appearance. The colour of the seals looks like cloth but it is actually moulded onto the seal, and it will never come off. Bristleflex seals take advantage of modern technology to produce a seal that fits well, looks good, and lasts a long time.

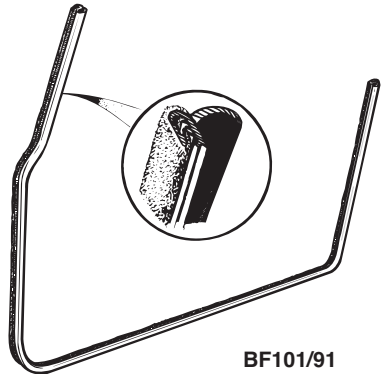

BF101/91

Part No.	Description	No. Off
	FUZZY DOOR SEALS , Bristleflex type, 91-inches	
BF101/91	Fuzzy Door Seal , black	2
BF102/91	Fuzzy Door Seal , bright red	2
BF107/91	Fuzzy Door Seal , shadow blue	2
BF103/91	Fuzzy Door Seal , dark tan	2
BF1031/91	Fuzzy Door Seal , light tan	2

DOOR SEALS—WOOL MOQUETTE FUZZY SEALS

These wool moquette seals are made of the same wool material used on original factory seals for British cars of the 1950's, 1960's, and 1970's. The cross-section is a little larger than original, but the rubber edge seal is pliable, and we do not see any problems with door closing. Since these seals were introduced a year or so ago, we have sold hundreds of them to satisfied customers.

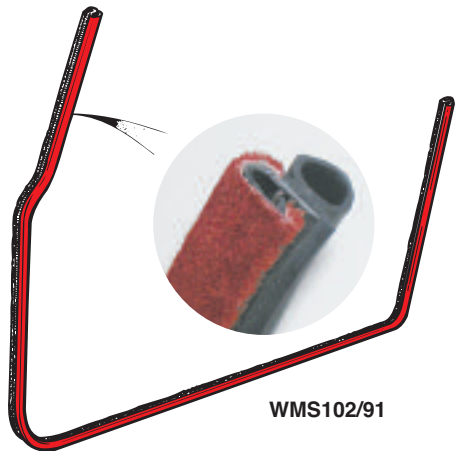

WMS102/91

Part No.	Description	No. Off
	FUZZY DOOR SEALS , wool moquette type	
WMS101/91	Fuzzy Door Seal , black	2
WMS102/91	Fuzzy Door Seal , bright red	2
WMS107/91	Fuzzy Door Seal , shadow blue	2
WMS103/91	Fuzzy Door Seal , dark tan	2
WMS1031/91	Fuzzy Door Seal , light tan	2

RUBBER BODY SEALS AND GASKETS

DOOR WINDOW SEALS



GHF1582

612806

612792

620403

620913

Part No.	Description	No. Off
612792	Seal , rubber, window scraper, outer, all Spitfires	2
613169	Clip , securing outer seals	14
612806	Seal , felt, window scraper, inner, all Spitfires	2
GHF1582	Clip , securing inner seals	14
620403	Seal , rubber, door glass to windscreen frame; thinner seal used on most Spitfire	2
620913	Seal , rubber, door glass to windscreen frame; thicker seal used on some Spitfires	2

HARD TOP SEALS, Spitfire mks.1, 2, 3, 1962-70

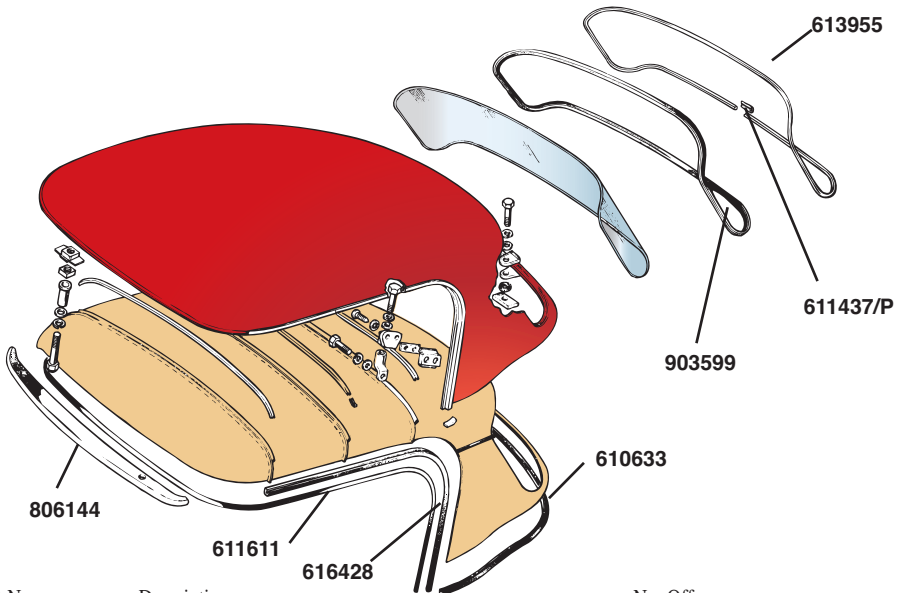

Part No.	Description	No. Off
903599	Seal , rubber, around rear window glass	1
613955	Trim Strip , chromed plastic, around rear window	1
611437/P	Clip , joint, chromed plastic	1
806144	Seal , rubber, hard top to windscreen frame	1
616428	Seal , rubber, around door window openings	2
611611	Fuzzy Draught Seal , runs around both door openings and front of hard top, black; other colors available on request	1
610633	Seal , rubber, hard top to rear deck	1

RUBBER BODY SEALS AND GASKETS

HARD TOP SEALS, Spitfire mk.4, 1500

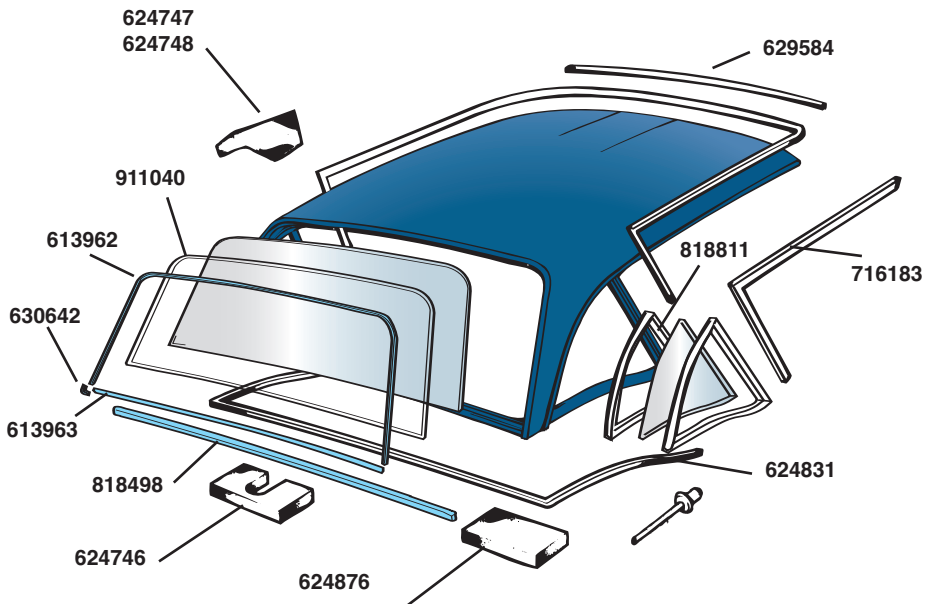

Part No.	Description	No. Off
911040	Seal , rubber, around rear window glass	1
613962	Trim Strip , chromed plastic, fitted to rear window seal, U-shaped piece	1
613963	Trim Strip , chromed plastic, fitted to rear window seal, straight piece	1
630642	Clip , corner joint, rear window trim strips	2
818801	Seal , rubber, quarter window, L.H.	1
818811	Seal , rubber, quarter window, R.H.	1
629584	Seal , rubber, front of hard top to top of windscreen	1
716183	Seal , rubber, door window openings; straight piece supplied—you must miter corner and assemble with adhesive	2
624831	Seal , hard top to rear deck	1
818498	Trim Strip , chromed, hard top rear	1
GHF1461	Clip , rivet, securing chromed trim strip	5
624746	Rubber Block , with U-shaped cut-out, hard top to rear deck	2
624876	Sponge Block , hard top to rear deck	1
624747	Sponge Block , hard top to rear deck, front, L.H	1
624748	Sponge Block , hard top to rear deck, front, R.H.	1

RUBBER BODY SEALS AND GASKETS

GROMMETS AND PLUGS

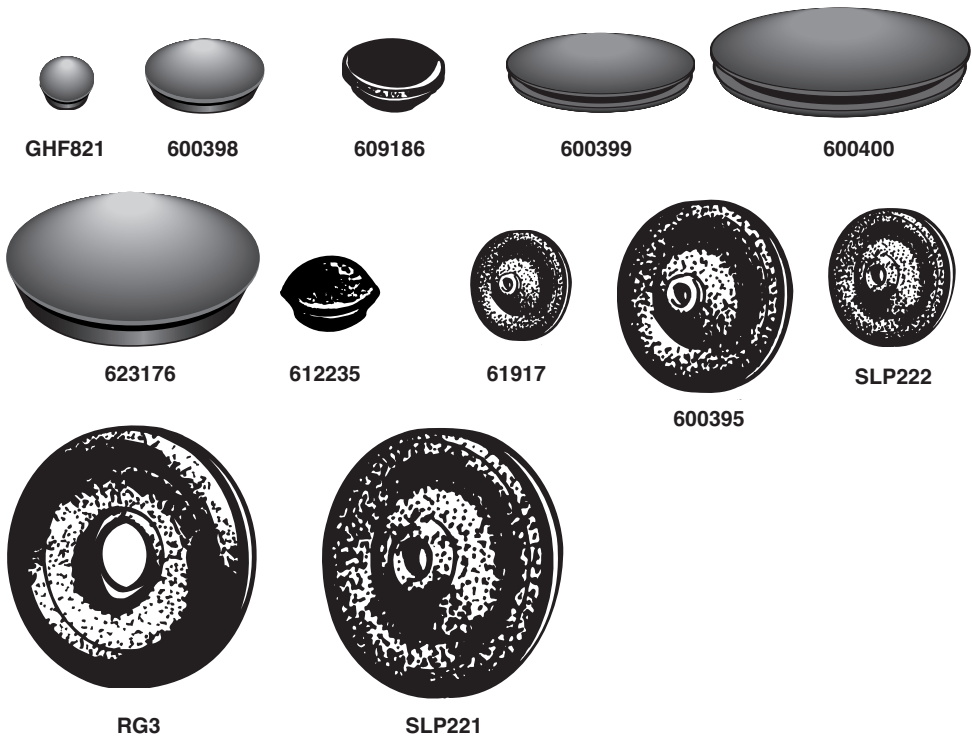

Part No.	Description	No. Off
----------	-------------	---------

RUBBER PLUGS

GHF821	Plug , 5/16-inch hole	A/R
600398	Plug , 1/2-inch hole	A/R
609186	Plug , 5/8-inch hole	A/R
600399	Plug , one-inch hole	A/R
600400	Plug , 1 1/2-inch hole	A/R
623176	Plug , 1 3/8-inch	A/R
600400	Plug , 1 1/2-inch	A/R
612235	Plug , in windscreen capping,	A/R

RUBBER GROMMETS

61917	Grommet , 1/2-inch hole, small cable entry	A/R
600395	Grommet , one-inch hole, larger cable entry	A/R
RG1	Grommet , large for wiring harnesses, 1 1/2-inch hole	A/R
RG3	Grommet , large for wiring harnesses, 1 7/8-inch hole	A/R
SLP221	Grommet , wiper tube, one-inch hole	A/R
SLP222	Grommet , wiper tube, 1 1/4-inch hole	A/R

RUBBER BODY SEALS AND GASKETS

BODY GASKETS

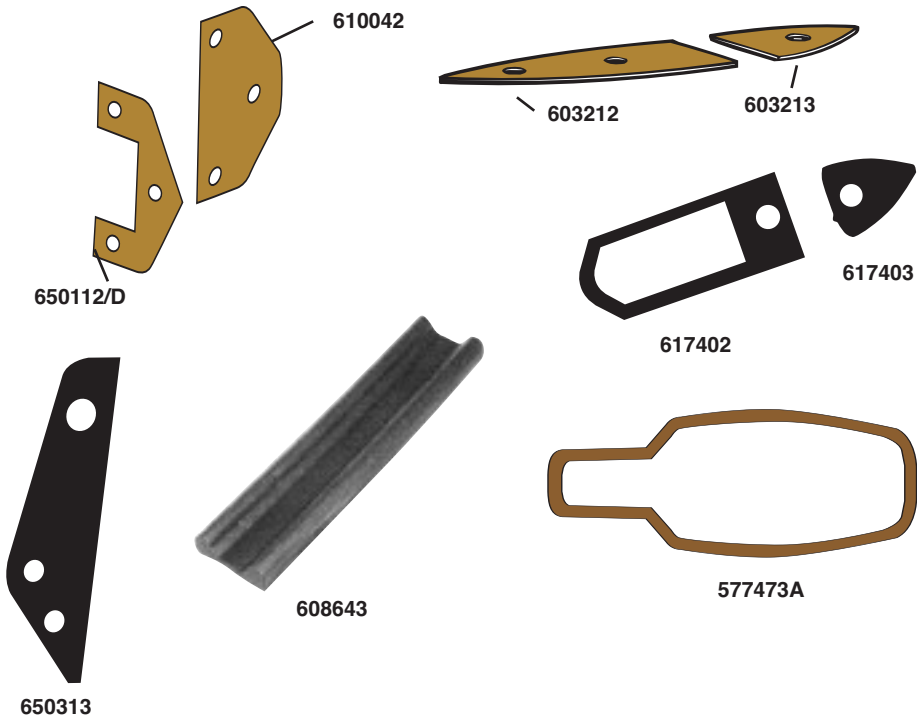

Part No.	Description	No. Off
617402	Gasket , door handle, large, Spitfire mk.2 after comm. no. FC56579, Spitfire mk.3	2
617403	Gasket , door handle, small, Spitfire mk.2 after comm. no. FC56579, Spitfire mk.3	2
577473A	Gasket , door handle, Spitfire mk.4, 1500	2
610042	Gasket , shim, door hinges to door post	A/R
650112/D	Gasket , shim, door hinges to doors	A/R
603212	Gasket , shim, trunk hinge, long end, Spitfire mks.1, 2, 3	A/R
603213	Gasket , shim, trunk hinge, short end, Spitfire mks.1, 2, 3	A/R
650313	Gasket , windscreen mounting brackets, Spitfire mks.1, 2, 3	2
608643	Rubber Pad , anti-rattle; fits between sheet metal and reinforcement tubes on early Spitfire trunk lids and all Spitfire bonnets; use 4 off for trunk lids and 2 off for bonnets	2-4