

ENGINE REBUILD COMPONENTS

“TRF Offers the Best Parts Money Can Buy for Your Spitfire Engine Rebuild”

ENGINE GASKET SETS

TRF offers gasket sets made by OEM supplier Payen, where available, as well as high-quality gaskets sets made by an after-market supplier.

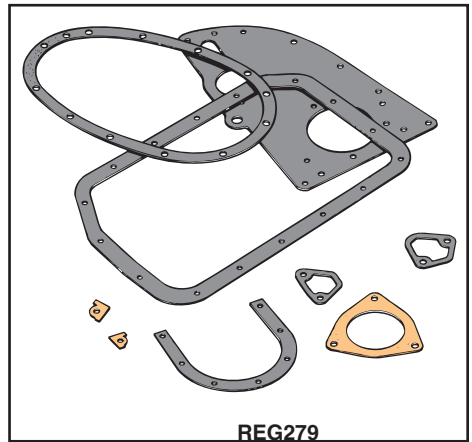
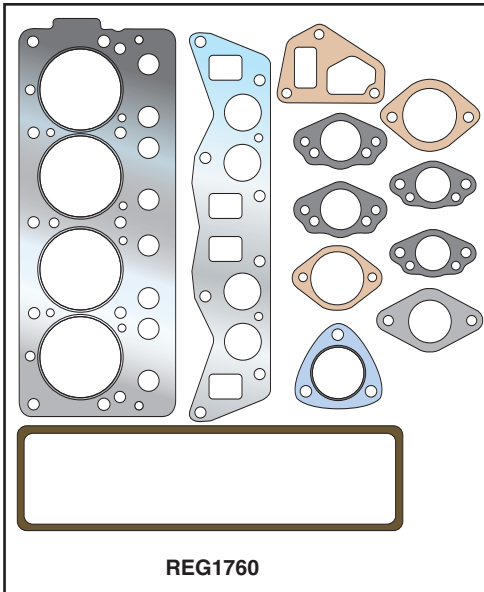

Part No.	Description	No. Off
REG183	Gasket Set , upper, Spitfire mks.1, 2; after-market brand	1
REG1182	Gasket Set , upper, Spitfire mk.3, after-market brand	1
AJM1149	Gasket Set , upper, Spitfire mk.4, 1971, Payen brand	1
REG1149	Gasket Set , upper, Spitfire mk.4, 1971, after-market brand	1
REG1209	Gasket Set , upper, Spitfire mk.4, 1972, after-market brand	1
REG1142	Gasket Set , upper, Spitfire 1500, 1973-74, after-market brand	1
REG1760	Gasket Set , upper, Spitfire 1500, 1975-80, after-market brand	1
REG279	Gasket Set , lower, all Spitfires, 1962-80, after-market brand	1

ENGINE REBUILD COMPONENTS

INDIVIDUAL ENGINE GASKETS

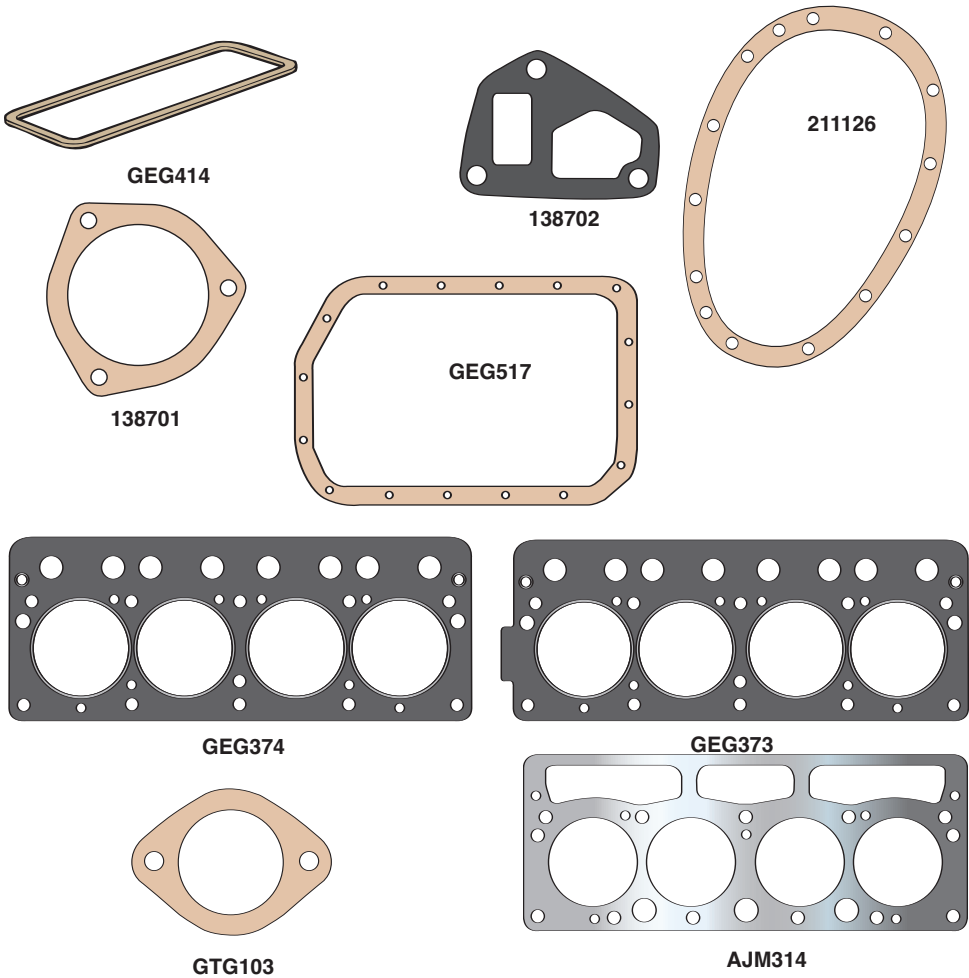

Part No.	Description	No. Off
GEG414	Gasket , valve cover, all Spitfires, 1962-80	1
GEG517	Gasket , oil pan, all Spitfires, 1962-80	1
211126	Gasket , timing cover, all Spitfires, 1962-80	1
138701	Gasket , water pump to housing, all Spitfires, 1962-80	1
138702	Gasket , water pump housing to block, all Spitfires, 1962-80	1
GTG103	Gasket , thermostat housing, all Spitfires, 1962-80	1
AJM314	Gasket , cylinder head, Spitfire mks.1, 2	1
GEG374	Gasket , cylinder head, Spitfire mks.3, 4 1968-71	1
GEG373	Gasket , cylinder head, Spitfire mk.4, 1500, 1972-80	1

ENGINE REBUILD COMPONENTS

ENGINE BEARING SETS, Spitfire mks.1, 2, 3, 1962-70

"High Quality Bi-Metal Bearings"



KBM899/STD

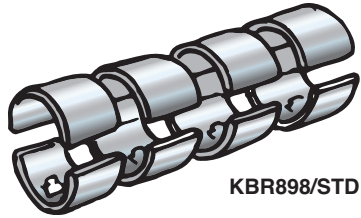

KBR898/STD

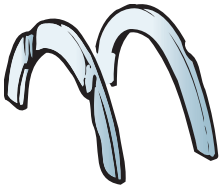

AEW2166/SASTD

Part No.	Description	No. Off
MAIN BEARING SETS,		
Spitfire mks.1, 2, 3		
KBM899/STD	Main Bearing Set , standard size	1
KBM899/010	Main Bearing Set , .010-inch undersize	1
KBM899/020	Main Bearing Set , .020-inch undersize	1
KBM899/030	Main Bearing Set , .030-inch undersize	1
ROD BEARING SETS, Spitfire		
mks.1, 2, 3		
KBR898/STD	Rod Bearing Set , standard size	1
KBR898/010	Rod Bearing Set , .010-inch undersize	1
KBR898/020	Rod Bearing Set , .020-inch undersize	1
KBR898/030	Rod Bearing Set , .030-inch undersize	1
THRUST WASHERS SETS, Spitfire		
mks.1, 2, 3		
AEW2166/SASTD	Thrust Washer Set , standard size	1
AEW2166/SA005	Thrust Washer Set , .005-inch oversize	1
AEW2166/SA010	Thrust Washer Set , .010-inch oversize	1
VPC978	Cam Bearing Set	1

ENGINE REBUILD COMPONENTS

ENGINE BEARING SETS, Spitfire mk.4, 1500, 1971-80

"High Quality Bi-Metal Bearings"

KBM91612/STD

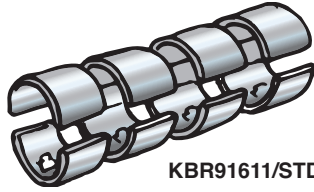

KBR91611/STD



VPW12/STD

Part No.	Description	No. Off
MAIN BEARING SETS, Spitfire mk.4, 1500		
KBM91612/STD	Main Bearing Set , standard size	1
KBM91612/010	Main Bearing Set , .010-inch undersize	1
KBM91612/020	Main Bearing Set , .020-inch undersize	1
KBM91612/030	Main Bearing Set , .030-inch undersize	1
ROD BEARING SETS, Spitfire mk.4, 1500		
KBR91611/STD	Rod Bearing Set , standard size	1
KBR91611/010	Rod Bearing Set , .010-inch undersize	1
KBR91611/020	Rod Bearing Set , .020-inch undersize	1
KBR91611/030	Rod Bearing Set , .030-inch undersize	1
THRUST WASHERS SETS, Spitfire mk.4, 1500		
VPW12/STD	Thrust Washer Set , standard size	1
AEW2171/005	Thrust Washer Set , .005-inch oversize	1
VPW12/010	Thrust Washer Set , .010-inch oversize	1
AEW2171/015	Thrust Washer Set , .015-inch oversize	1

ENGINE OIL SEALS

125631

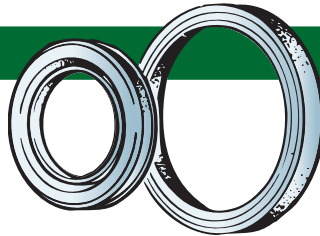

143456

Part No.	Description	No. Off
100499	Oil Seal , timing cover, Spitfire mks. 1, 2, 3	1
125631	Oil Seal , timing cover, Spitfire mk.4, 1500	1
143456	Oil Seal , rear, all Spitfire	1

ENGINE REBUILD COMPONENTS

CONNECTING RODS

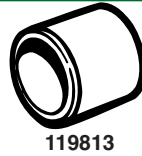

119813

146454

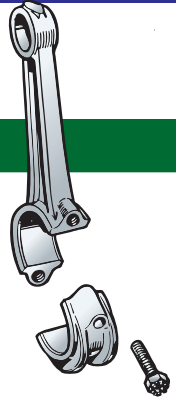

Part No.	Description	No. Off
146454	Connecting Rod , Spitfire mk.4, 1500	4
119813	Small End Bush , all Spitfire	4

FLYWHEEL RING GEAR

201350

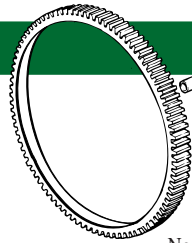

105143

Part No.	Description	No. Off
201350	Ring Gear , all Spitfire	1
105143	Bush , pilot, all Spitfire	1

PISTON SETS

Original AE Hepolite pistons are no longer available for the Spitfire. Listed below are piston sets made by a company that has been making pistons for a number of years. Pistons are sold in sets of four only. Each piston includes rings and wrist pins. Available sizes are standard, and oversizes in .020", .030", and .040". Please state size needed when ordering.



Part No.	Description	No. Off
CBP18690	Piston Set , full floating type, with rings and pins, Spitfire mks.1, 2 up to engine no. FC71116 and from engine no. FC89950 on.	1
CBP18261	Piston Set , press-fit type, Spitfire mk.2 from engine no. FC71117 up to FC89949	1
CBP18262	Piston Set , full floating type; Spitfire mks.3, 4 with 1296cc high compression engine	1
CBP20140	Piston Set , full floating type; Spitfire mks. 3, 4 with 1296cc low compression engine; use high compression piston sets listed above	1
CBP20139	Piston Set , Spitfire 1500 high compression engine, Spitfire 1500	1
CBP19708	Piston Set , Spitfire 1500, low compression engine; use high compression piston sets listed above	1

ENGINE REBUILD COMPONENTS

PISTON RING SETS

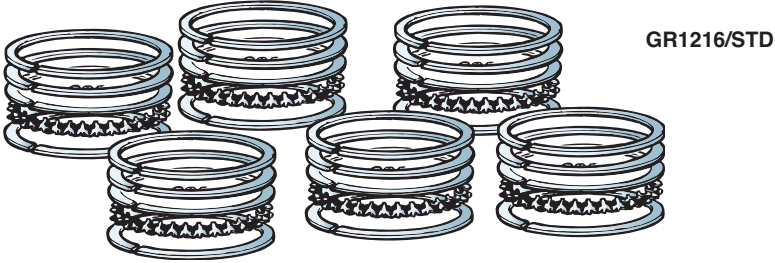
"Famous Grant Brand Piston Ring Sets"

Part No.	Description	No. Off
PISTON RING SETS, Spitfire mks.1, 2		
GR1216/STD	Piston Ring Set , standard size	1
GR1216/020	Piston Ring Set , .020-inch oversize	1
GR1216/030	Piston Ring Set , .030-inch oversize	1
GR1216/040	Piston Ring Set , .040-inch oversize	1
PISTON RING SETS, Spitfire mks.3, 4		
GR1286/STD	Piston Ring Set , standard size	1
GR1286/020	Piston Ring Set , .020-inch oversize	1
GR1286/030	Piston Ring Set , .030-inch oversize	1
GR1286/040	Piston Ring Set , .040-inch oversize	1
PISTON RING SETS, Spitfire 1500		
GR1398/STD	Piston Ring Set , standard size	1
GR1398/020	Piston Ring Set , .020-inch oversize	1
GR1398/030	Piston Ring Set , .030-inch oversize	1
GR1398/040	Piston Ring Set , .040-inch oversize	1

CAMSHAFTS

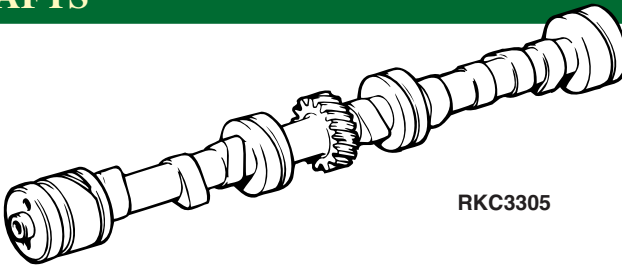

Part No.	Description	No. Off
211433	Camshaft , Spitfire mk.1 from engine no. FC38628E to FC50000E	1
212164	Camshaft , Spitfire mk.2, 3 up to engine no. FE8155E	1
RKC3305	Camshaft , mk.3 after engine no. FE8155E, mk.4, 1500	1
105114	Plate , locating camshaft to block	1
HU807	Set Screw , locating plate to block	2
WL208	Washer , lock, locating plate to block	2

ENGINE REBUILD COMPONENTS

CAM BEARINGS

Cam bearings were fitted to Spitfire mk.2 engines beginning at engine no. FC61023E and were then fitted to all Spitfire mk.3, and Spitfire mk.4 up to engine no. FH25000

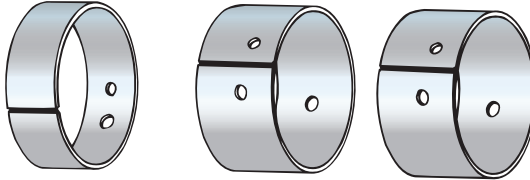

VPC978

Part No.	Description	No. Off
VPC978	Cam Bearing Set , front and rear	1

TIMING COMPONENTS

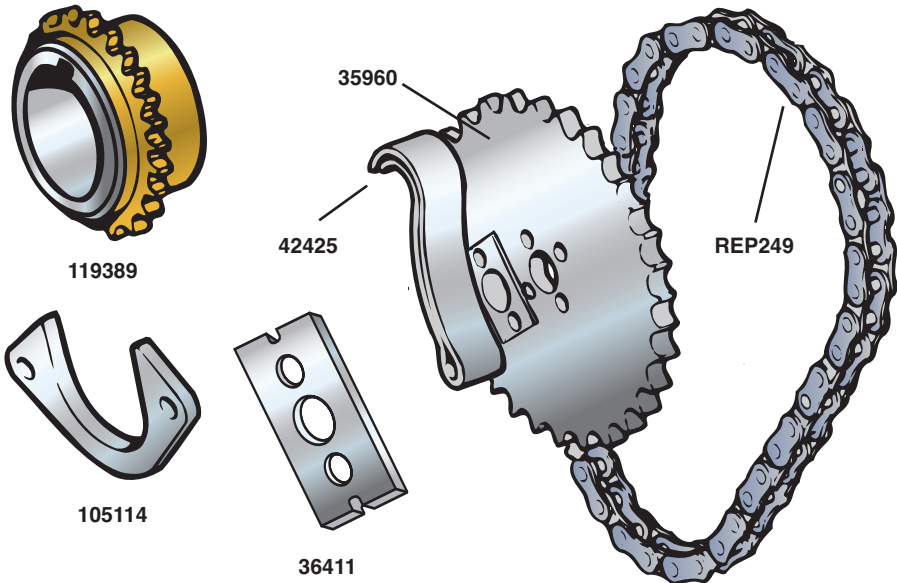

Part No.	Description	No. Off
100431	Timing Gear , crankshaft, Spitfire mks. 1, 2, 3	1
119389	Timing Gear , crankshaft, Spitfire mk.4, 1500	1
35960	Timing Gear , camshaft, all Spitfire	1
36411	Plate , locking, camshaft, all Spitfire	1
REN105131	Timing Chain , original Renold brand, all Spitfire	1
REP249	Timing Chain , all Spitfire	1
42425	Tensioner , timing chain, all Spitfire	1
33214	Pin , anchor, tensioner, all Spitfire	1
105114	Plate , locating camshaft to block	1
HU807	Set Screw , locating plate to block	2
WL208	Washer , lock, locating plate to block	2

ENGINE REBUILD COMPONENTS

VALVE TAPPETS—LIFTERS



143552

Part No.	Description	No. Off
144343	Valve Tappet , Spitfire mk.1, mk.2 up to eng. no. FE8155E	8
143552	Valve Tappet , Spitfire mk.2 after eng. no. FE8155E, Spitfire mks.3, 4, 1500	8

ROCKER SHAFTS AND ROCKERS



104829

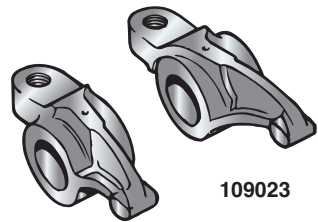

109023

Part No.	Description	No. Off
104829	Rocker Shaft , Spitfire mks.1, 2	1
144962	Rocker Shaft , Spitfire mks.3, 4, 1500	1
109024	Rocker , nos. 1, 3, 5, and 7, all Spitfire	4
109023	Rocker , nos. 2, 4, 6, and 8, all Spitfire	4
57109	Screw , valve adjusting, Spitfire mks.1,2, 3	8
109495	Screw , valve adjusting, Spitfire mk.4, 1500	8
57110	Nut , locking adjusting screw, all Spitfire	8

ROCKER ASSEMBLIES

“Complete Assemblies Ready to Install”

TRF offers complete rocker assemblies ready to bolt onto your Spitfire. Rocker shafts are welded up and chromed and then are reground to stock specifications. Rockers are bushed and refaced. Core units are scarce for earlier applications so the customer's rocker assembly needs to be sent to TRF to be rebuilt and returned.

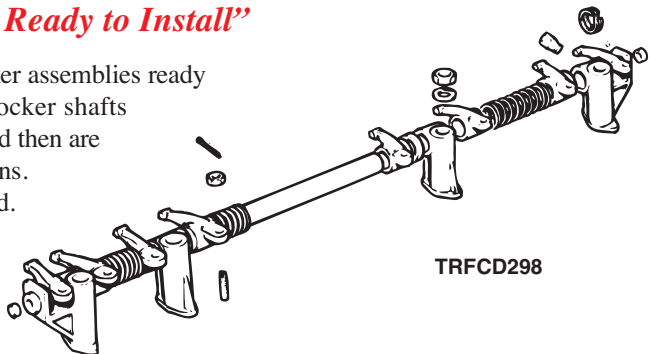

TRFCD298

Part No.	Description	No. Off
TRFCD297	Rocker Assembly , rebuilt, Spitfire mks. 1, 2	1
CORE 30	Core charge on above	1
TRFCD298	Rocker Assembly , rebuilt, Spitfire mks. 3, 4, and 1500	1
CORE30	Core charge on above	1