

# ENGINE REBUILD COMPONENTS

## ROLLER ROCKER ASSEMBLIES

*“Achieve More Performance With a Roller Rocker Kit.”*

Roller rocker assemblies are available for 1296 and 1500 Spitfire engines. For the earlier 1147cc engines, complete assemblies are not available but a kit containing roller rockers and a hardened shaft is available to allow you to build an assembly using your own pedestals. Roller rockers run with needle bearings on a hardened rocker shaft. The rocker contacts the valve stem via a roller bearing on the rocker tip, reducing side loads which wear valve stems and guides. Stock rockers have a 1.43:1 ratio, and the higher the ratio of the roller rockers improves engine performance by opening valves faster and farther. This increases air and fuel flow into the cylinders and provides a net horsepower increase of as much as 10%.



Part No.	Description	No. Off
	<b>ROLLER ROCKER KITS</b> , Spitfire mks.1, 2; includes roller rockers and a hardened shaft	
HP265	<b>Roller Rocker Kit</b> , 1.55:1 ratio	1
HP266	<b>Roller Rocker Kit</b> , 1.65:1 ratio	1
	<b>ROLLER ROCKER ASSEMBLIES</b> , Spitfire mks.3, 4, and Spitfire 1500; includes roller rockers, hardened shaft, and pedestals	
HP267	<b>Roller Rocker Assembly</b> , 1.55:1 ratio	1
HP268	<b>Roller Rocker Assembly</b> , 1.65:1 ratio	1

## VALVES—INTAKE AND EXHAUST

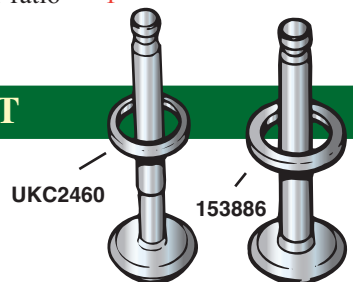

Part No.	Description	No. Off
134464	<b>Valve</b> , intake, Spitfire mks.1, 2	4
126893	<b>Valve</b> , intake, Spitfire mk.3, 4 up to eng. no. FK25000UE	4
145328	<b>Valve</b> , intake, Spitfire mk.4 after engine no. FK25001UE, 1500 through 1974	4
UKC2460	<b>Valve</b> , intake, Spitfire 1500, 1975 on	4
131179	<b>Valve</b> , exhaust, Spitfire mk.1, 2	4
144965	<b>Valve</b> , exhaust, Spitfire mk.3 up to engine no. FE8155E	4
153886	<b>Valve</b> , exhaust, Spitfire mk.3, after engine no. FE8155E, mk.4, 1500	4

## ENGINE REBUILD COMPONENTS

## VALVE GUIDES



Part No.	Description	No. Off
	<b>VALVE GUIDES, cast iron</b>	
111869	Valve Guide, Spitfire mk.1, 2	8
58923	Valve Guide, Spitfire mk.3, 4, 1500	8
	<b>VALVE GUIDES, bronze</b>	
TRFCD14	Valve Guide, bronze, Spitfire mk.1, 2	8
TRFCD13	Valve Guide, bronze, Spitfire mk.3, 4, 1500	8
HP263	Valve Guide Set, machined to take valve stem seals; full set with bronze guides and Teflon seals, Spitfire mks.1, 2	1
HP264	Valve Guide Set, machined to take valve stem seals; full set with bronze guides and Teflon seal, Spitfire mks.3, 4, and 1500	1

## VALVE SPRINGS AND COLLARS

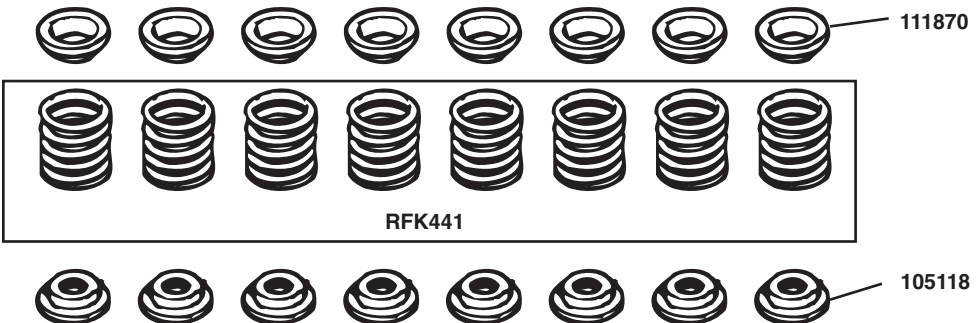

Part No.	Description	No. Off
	<b>VALVE SPRING SETS</b>	
RFK447	Valve Spring Set, Spitfire mks.1, 2, 3, 4 up to eng. no. FK25000E	1
RFK441	Valve Spring Set, Spitfire mk.4 after eng. no. FK25001E,1500	1
	<b>VALVE SPRING COLLARS</b>	
105118	Collar, lower, all Spitfire	8
111870	Collar, upper, all Spitfire	8
106663	Collar, split, all Spitfire, supplied in pairs	8

# ENGINE REBUILD COMPONENTS

## PUSH RODS

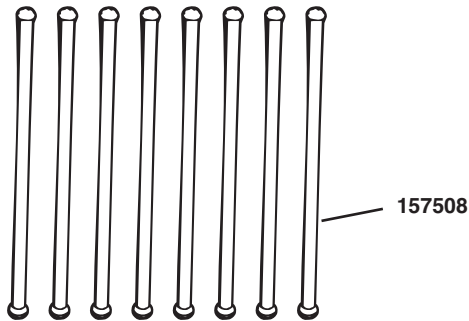

Part No.	Description	No. Off
104824	<b>Push Rod</b> , Spitfire mks.1, 2, low compression	8
111874	<b>Push Rod</b> , Spitfire mks.1, 2, high compression	8
111874	<b>Push Rod</b> , Spitfire mk.4 up to engine no. FK25000E	8
157508	<b>Push Rod</b> , Spitfire mk.4 after eng. no. FK25000E, 1500	8
TRFCD123	<b>Tubular Push Rod Set</b> , stronger and lighter. at high R.P.M.; can be shortened	1

## ENGINE MOUNTS

### ENGINE AND GEARBOX MOUNTS

*“Reduce Engine and Gearbox Movement”*

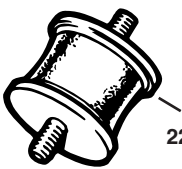

22G2205



159656

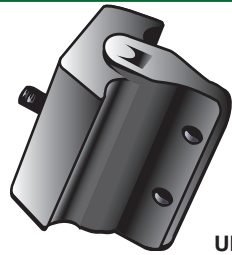

UKC5334

Part No.	Description	No. Off
UKC5334	<b>Engine Mount</b> , front, all Spitfire	2
22G2205	<b>Gearbox Mount</b> , all Spitfire without overdrive	2
159656	<b>Gearbox Mount</b> , Spitfire mk.3 after comm. no. FD25746, mk.4, and 1500, cars with overdrive	1

## ENGINE REBUILD COMPONENTS

### ALLOY VALVE COVERS

*“Dress Up Your Engine Compartment with an Alloy Valve Cover”*

The addition of an alloy valve cover has several benefits. The covers provide a nice way to dress up the engine compartment of your Spitfire, and provide better heat dissipation than a stock cover. Also, an alloy cover won't crush down when you tighten the nuts which secure it to the cylinder head. Available now in three different finishes.

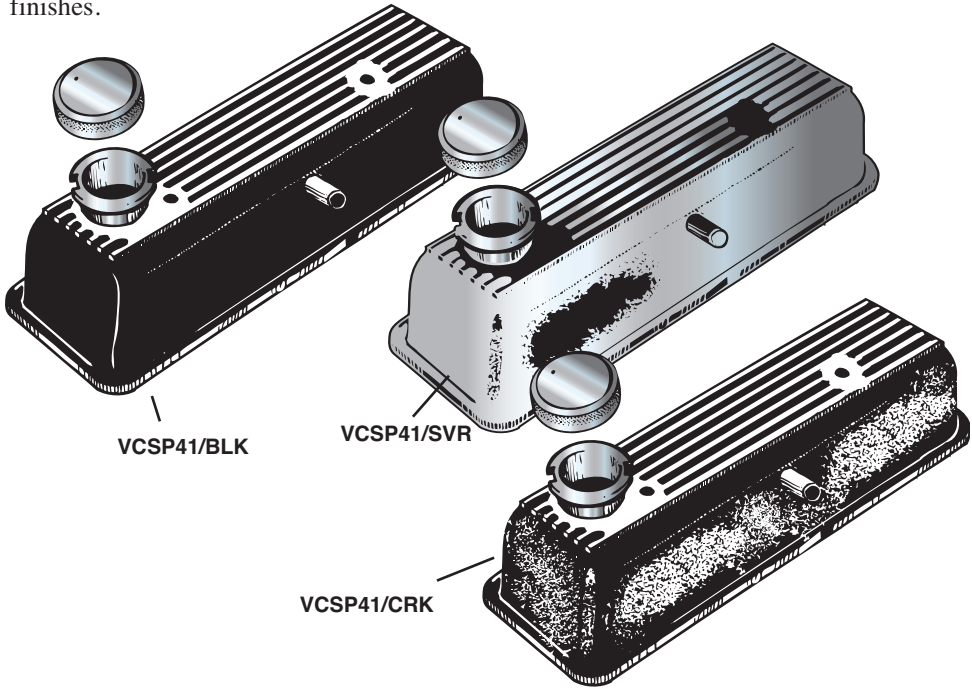

Part No.	Description	No. Off
VCSP41/SVR	<b>Valve Cover</b> , cast aluminium, polished silver finish	1
VCSP41/BLK	<b>Valve Cover</b> , cast aluminium, black finish with polished silver details	1
VCSP41/CRK	<b>Valve Cover</b> , cast aluminium, black crackle finish with polished silver details	1
GEG414	<b>Gasket</b> , valve cover to head	1

## ENGINE LUBRICATION

## OIL PUMP

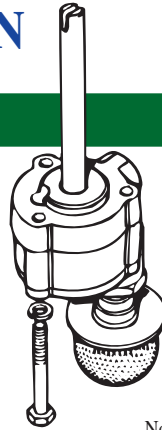

TKC1975

Part No.	Description	No. Off
TKC1975	<b>Oil Pump</b> , all Spitfire	1

## OIL PRESSURE RELIEF COMPONENTS



RFK778

Part No.	Description	No. Off
RFK778	<b>OIL PRESSURE RELIEF VALVE KIT</b> , all Spitfire	1
132107	<b>Piston</b> , oil pressure relief	1
131535	<b>Spring</b> , oil pressure relief	1
107246	<b>Plug</b> , retaining piston and spring	1
6K433	<b>Washer</b> , sealing plug	1

## OIL PRESSURE SENDING UNITS

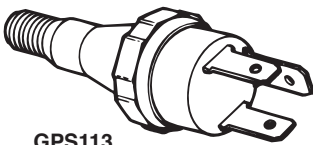

GPS113

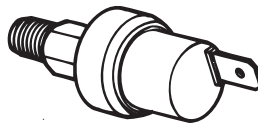

GPS117

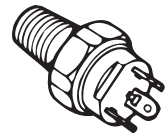

GPS123

Part No.	Description	No. Off
GPS117	<b>Oil Pressure Sending Unit</b> , one prong, Spitfire mks.1, 2, 3, 4	1
GPS113	<b>Oil Pressure Sending Unit</b> , three prong, Spitfire 1500 Federal models up to eng. no. FM80001, and Spitfire 1500 California models up to eng. no. FM10369UCE	1
GPS117	<b>Oil Pressure Sending Unit</b> , one prong, Spitfire 1500 Federal models from eng. no. FM80001 up to comm. no. FM110001	1
GPS123	<b>Oil Pressure Sending Unit</b> , three prong, Spitfire 1500 Federal models after comm. no. FM110001, California 1500 models after eng. no. FM10369UCS	1

## ENGINE LUBRICATION

## OIL DRAIN PLUGS



114774



155660



32307

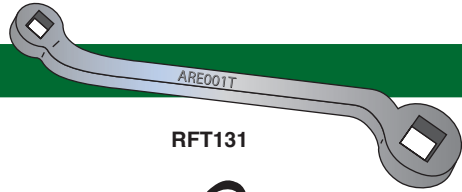

RFT131



UKC3997

UKC3996

Part No.	Description	No. Off
114774	<b>Oil Drain Plug</b> , square head type, all Federal models	1
114774	<b>Oil Drain Plug</b> , square head type, California models up to comm. no. FM59342	1
155660	<b>Oil Drain Plug</b> , magnetic, for applications listed above	1
UKC3996	<b>Oil Drain Plug</b> , bolt with hole to dipstick tube to oil pan on later California models, after comm. no. FM59342	1
UKC3997	<b>Sealing Washer</b> , for later California oil drain plug	2
32307	<b>Felt Washer</b> , dipstick	1
RFT131	<b>Combination Tool</b> , for hex head drain plugs, all Federal models, early California models	1

## EXTERNAL OIL FEED PIPE KITS

*“Reduce Rocker Shaft Wear with an External Oil Pipe Kit”*

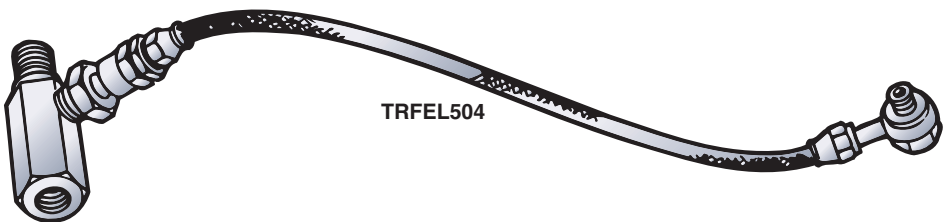

TRFEL504

Part No.	Description	No. Off
TRFEL504	<b>External Oil Feed Kit</b> , increases flow of oil from engine block to cylinder head to reduce engine wear	1

# ENGINE LUBRICATION

## OIL FILLER CAPS

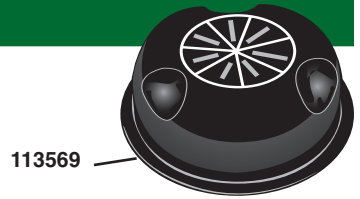
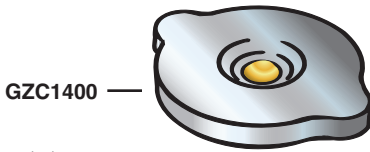

Part No.	Description	No. Off
113569	<b>Oil Filler Cap</b> , Spitfire mks.1, 2	1
GZC1400	<b>Oil Filler Cap</b> , Spitfire mks.3, 4, 1500	1

## OIL COOLERS

*“Just Like the Race Cars Have”*

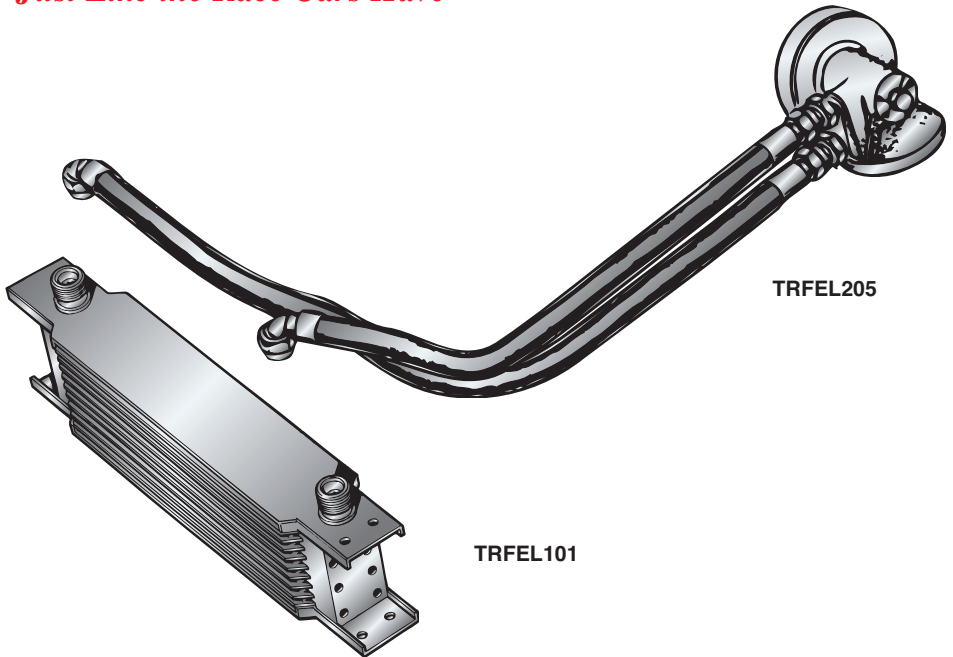

Part No.	Description	No. Off
<b>OIL COOLER RADIATORS</b>		
TRFEL101	<b>Oil Cooler Radiator</b> , 13-row	1
TRFEL102	<b>Oil Cooler Radiator</b> , 16-row	1
<b>OIL COOLER FITTING KITS</b>		
TRFEL205	<b>Oil Cooler Fitting Kit</b> , with rubber hoses	1
TRFEL208	<b>Oil Cooler Fitting Kit</b> , with braided hoses	1

## FUEL SYSTEM

## FUEL PUMPS

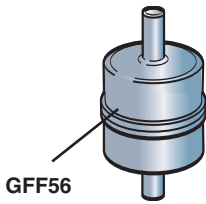

GFF56

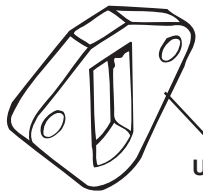

UKC8523

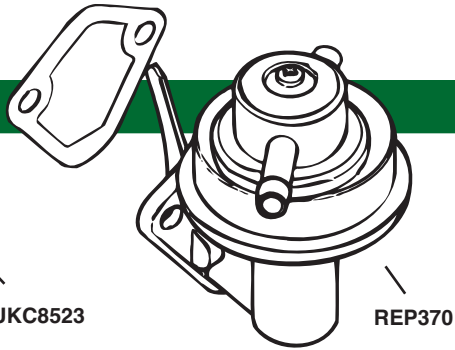

REP370

Part No.	Description	No. Off
REP368	<b>Fuel Pump</b> , Spitfire mks.1, 2, 3, 4	1
138591	<b>Gasket</b> , fuel pump to block for above fuel pump	1
REP369	<b>Fuel Pump</b> , Spitfire, early 1500 up to comm. no. FM93157, pump has straight arm, no spacer between the pump and the engine block; fitted from 1973 to mid 1978	1
138791	<b>Gasket</b> , fuel pump to block for above fuel pump	1
REP370	<b>Fuel Pump</b> , Spitfire 1500 after comm. no. FM93157; pump has curved arm and a spacer is fitted between the fuel pump and the engine block; mid 1978 on	1
UKC8523	<b>Spacer</b> , fuel pump to block for above pump	1
GFF56	<b>Fuel Filter</b> , AC brand	1

## CARBURETTOR REBUILD KITS



Part No.	Description	No. Off
SU700	<b>Carb Rebuild Kit</b> , Spitfire mks.1, 2 with dual SU carbs; includes gaskets, metering needles, jets, and needle float valves; does two carbs	1
SU111	<b>Carb Rebuild Kit</b> , Spitfire mk.3, 1968-69 with dual SU carbs ; includes gaskets, metering needles, jets, and needle float valves; does two carbs	1
ZEMS576B	<b>Carb Rebuild Kit</b> , Spitfire mk.3 1970, mk.4, 1500 with single Zenith Stromberg carb	1

# FUEL SYSTEM

## CARB ADJUSTING TOOLS

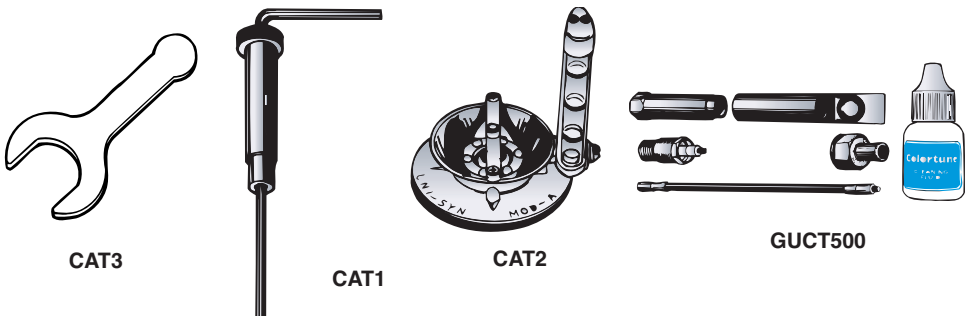

Part No.	Description	No. Off
CAT3	<b>Jet Adjusting Tool</b> , SU carbs	1
CAT1	<b>Adjusting Tool</b> , fuel-air mixture, Zenith-Stromberg carbs	1
CAT2	<b>Unisyn Air Flow Meter</b> , for synchronizing dual carburetors	1
GUCT500	<b>Gunsong Colortune Kit</b> , allows you to view engine combustion to adjust fuel-air mixture	1

## CHOKE CABLES AND KNOBS

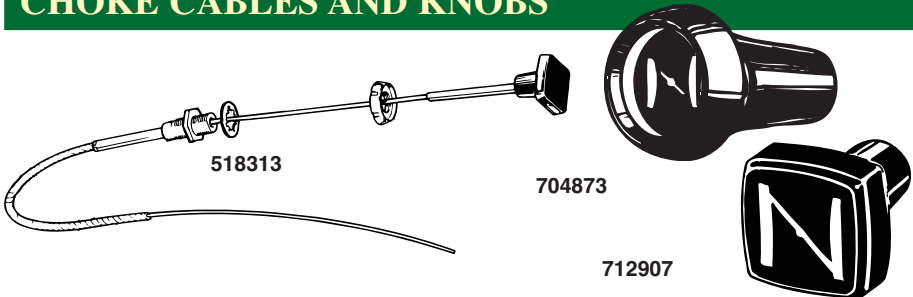

Part No.	Description	No. Off
<b>CHOKE CABLES</b>		
401900-1	<b>Choke Cable Assembly</b> , without knob, Spitfire mks.1, 2 and mk.3 up to comm. no. FDU31254	1
518314	<b>Choke Cable</b> , outer, Spitfire mk.3 after comm. no. FDU31254, mk.4, 1500	1
518313	<b>Choke Cable</b> , inner, Spitfire mk.3 after comm. no. FDU31254, mk.4 up to comm. no. FK30442U, with knob	1
521057	<b>Choke Cable</b> , inner, Spitfire mk.4 after comm. no. FK30442U, Spitfire 1500	1
<b>CHOKE KNOBS</b>		
704873	<b>Knob</b> , choke, Spitfire mks.1, 2; round knob with choke symbol	1
712907	<b>Knob</b> , Spitfire mk.3 after comm. no. FDU31254, mk.4; square knob with choke symbol	1